

# MINEWSEMI

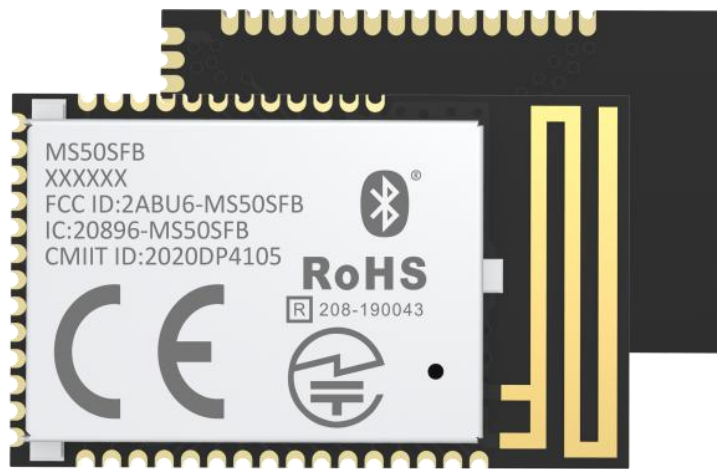

# MS50SFB

**Bluetooth Low Energy module**

**Specification V1.0**

---

# Small-sized nRF52811 Module MS50SFB Specification

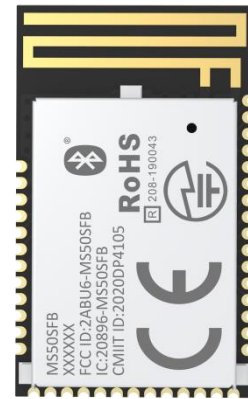

The MS50SFB is a compact and small size Bluetooth 5.1 module with ultra-low power consumption and optional antenna types; The module has the large number of GPIOs and excellent RF performance.

## Features

1. Frequency: 2400 to 2483 MHz
2. Max. Output power: +4dBm
3. Single power supply: 1.7 – 3.6V
4. Range: up to 60 meters in open space
5. Chip: nRF52811 (Nordic)
6. GPIO Quantity: 30
7. 192KB Flash and 24KB RAM (nRF52811)
8. Module size: 20.0 x 12.0 x 2.0 mm
9. ARM Cortex-M4 processor
10. Metal shielding with marking
11. UART communication protocol (Slave optional)
12. Antenna: PCB,chip antenna, u.FL/IPEX connector
13. Operating Temperature range: -40 to 85 degree Celsius
14. Range: up to 200 meters in open

## Application

1. Medical devices
2. Heart rate monitor
3. Blood pressure monitor
4. Blood glucose meter
5. Thermometer
6. Sport facilities
7. Weighing machine
8. Sports and fitness sensors
9. Accessories
10. 3D glasses and gaming controller
11. Mobile accessories
12. Remote controllers / Toys
13. Electronic devices
14. Cycle computer

# INDEX

1 Product Introduction .....	- 4 -
1.1 Ordering information .....	- 4 -
2 Pin Description .....	- 5 -
2.1 Pin assignment .....	- 5 -
2.1.1 MS50SFB PCB Antenna .....	- 5 -
2.1.2 MS50SFB chip Antenna .....	- 5 -
2.1.3 MS50SFB u.FL/IPEX connector .....	- 6 -
2.2 Pin definition .....	- 6 -
2.3 Block diagram .....	- 8 -
2.4 Mechanical Drawing .....	- 9 -
2.4.1 MS50SFB PCB Antenna .....	- 9 -
2.4.2 MS50SFB chip Antenna .....	- 9 -
2.4.3 MS50SFB u.FL/IPEX connector .....	- 10 -
3 Electrical Specification .....	- 11 -
3.1 Absolute maximum ratings .....	- 11 -
3.2 Recommended operating conditions .....	- 12 -
3.3 Electronic characteristic .....	- 12 -
3.3.1 General radio characteristics .....	- 12 -
3.3.2 Radio current consumption (Transmitter) .....	- 12 -
3.3.3 Radio current consumption (Receiver) .....	- 13 -
3.3.4 Transmitter specification .....	- 14 -
3.3.5 Receiver operation .....	- 15 -
3.3.6 RX selectivity .....	- 16 -
3.3.7 RX intermodulation .....	- 17 -
3.3.8 Radio timing .....	- 18 -
3.3.9 Received signal strength indicator (RSSI) specifications .....	- 18 -
4 Electrical Schematic .....	- 19 -
5 Package Information .....	- 20 -
5.1 Package dimension .....	- 20 -
5.2 Mark on metal shield .....	- 21 -
6 Reflow and Soldering .....	- 22 -
7 Certification .....	- 23 -
7.1 CE Certification .....	- 23 -
7.2 FCC Certification .....	- 23 -
7.3 Full Bluetooth Declaration ID .....	- 24 -
7.4 Canada (IC) .....	- 24 -
7.5 Japan (TELEC) .....	- 24 -
7.6 KC .....	- 24 -
7.7 India(WPC) .....	- 25 -
7.8 RCM .....	- 25 -
7.9 Environmental .....	- 25 -
7.9.1 RoHs .....	- 25 -
7.9.2 Reach .....	- 25 -
8 Notes & Cautions .....	- 26 -
8.1 Design notes .....	- 26 -
8.2 Layout notes .....	- 26 -
8.3 Installation and soldering .....	- 27 -
8.4 Handling and storage .....	- 27 -
8.5 Life support applications .....	- 28 -
9 Disclaimer .....	- 29 -
Revision History .....	- 29 -
COPYRIGHT STATEMENT .....	- 30 -

# 1 Product Introduction

The MS50SFB is a compact and small size Bluetooth 5.1 module with ultra-low power consumption and optional antenna types; The module has the large number of GPIOs and excellent RF performance. Therefore, it can apply to a wide range of Bluetooth connected products. With an ARM Cortex™ M4 MCU, up to 192KB flash, 24KB RAM, embedded 2.4GHz, MS50SFB can save the R&D and time cost.

The module is highly integrated that contains all the necessary components from radio to a different antenna and a completely implemented Bluetooth protocol stack and programming UART communication protocol.

## 1.1 Ordering information

Ordering number	Description
MS50SFB-1Y10AIR	nRF52810-QFAA BT 5.0 Module, with 32.768K, PCB Antenna
MS50SFB-2Y10AIR	nRF52810-QFAA BT 5.0 Module, with 32.768K, Chip Antenna
MS50SFB-3Y10AIR	nRF52810-QFAA BT 5.0 Module, with 32.768K, u.FL/IPEX connector

## 2 Pin Description

### 2.1 Pin assignment

#### 2.1.1 MS50SFB PCB Antenna

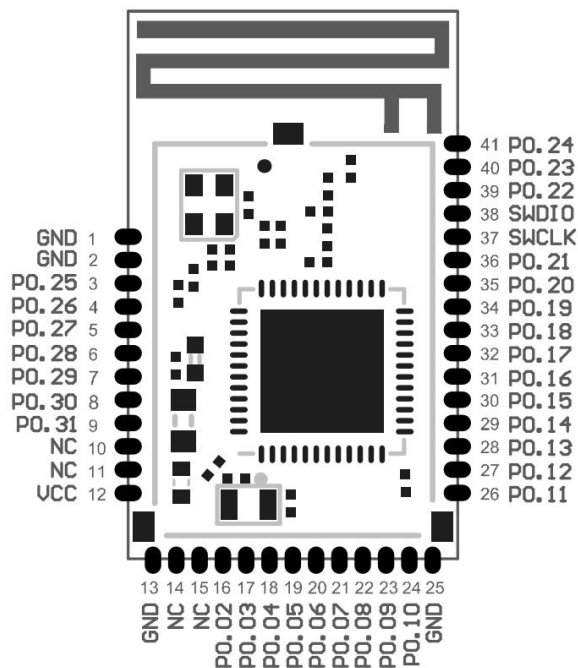

#### 2.1.2 MS50SFB chip Antenna

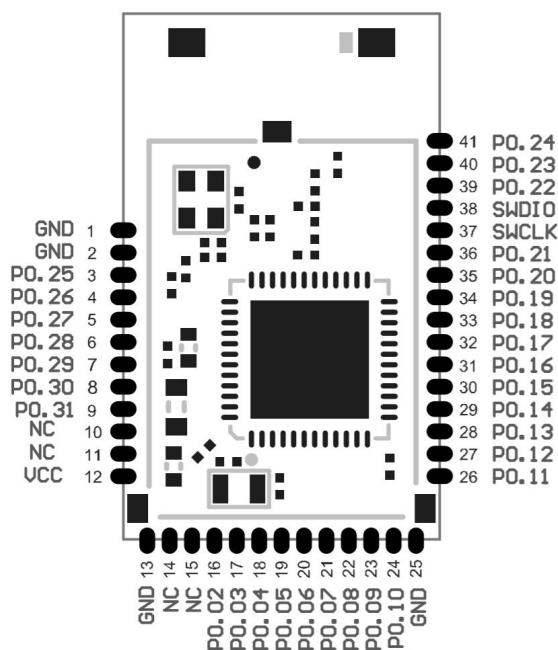

## 2.1.3 MS50SFB u.FL/IPEX connector

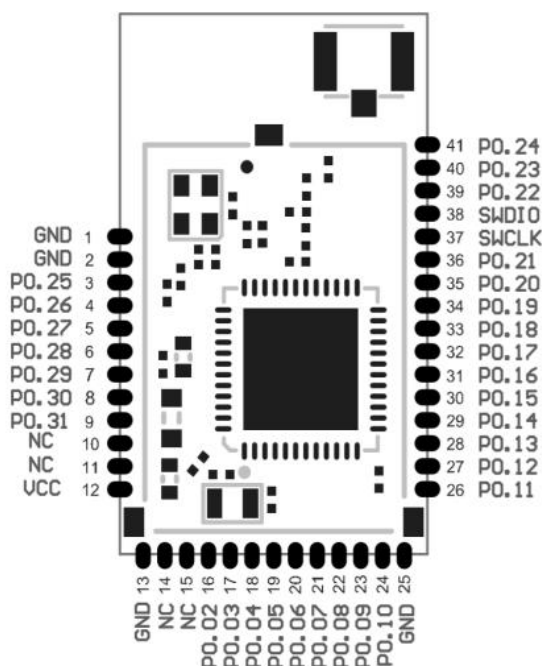

## 2.2 Pin definition

Symbol	Type	Description
P0.00	Digital I/O	General purpose I/O
XL1	Analog input	Connection for 32.768 kHz crystal (LFXO)
P0.01	Digital I/O	General purpose I/O
XL2	Analog input	Connection for 32.768 kHz crystal (LFXO)
P0.02	Digital I/O	General purpose I/O
AIN 0	Analog input	SAADC/COMP/LPCOMP input
P0.03	Digital I/O	General purpose I/O
AIN 1	Analog input	SAADC/COMP/LPCOMP input
P0.04	Digital I/O	General purpose I/O
AIN 2	Analog input	SAADC/COMP/LPCOMP input
P0.05	Digital I/O	General purpose I/O
AIN 3	Analog input	SAADC/COMP/LPCOMP input
P0.06	Digital I/O	General purpose I/O
P0.07	Digital I/O	General purpose I/O
P0.08	Digital I/O	General purpose I/O
P0.09	Digital I/O	General purpose I/O

P0.10	Digital I/O	General purpose I/O
GND	Ground	
P0.11	Digital I/O	General purpose I/O
P0.12	Digital I/O	General purpose I/O
P0.13	Digital I/O	General purpose I/O
P0.14	Digital I/O	General purpose I/O
TRACEDATA[3]	Digital I/O	Trace port output
P0.15	Digital I/O	General purpose I/O
TRACEDATA[2]	Digital I/O	Trace port output
P0.16	Digital I/O	General purpose I/O
TRACEDATA[1]	Digital I/O	Trace port output
P0.17	Digital I/O	General purpose I/O
P0.18	Digital I/O	General purpose I/O
TRACEDATA[0] / SWO	Digital I/O	Single wire output Trace port output
P0.19	Digital I/O	General purpose I/O
P0.20	Digital I/O	General purpose I/O
TRACECLK	Digital I/O	Trace port clock output
P0.21	Digital I/O	General purpose I/O
nRESET	Digital I/O	Configurable as pin reset
P0.22	Digital I/O	General purpose I/O
P0.23	Digital I/O	General purpose I/O
P0.24	Digital I/O	General purpose I/O
P0.25	Digital I/O	General purpose I/O
P0.26	Digital I/O	General purpose I/O
P0.27	Digital I/O	General purpose I/O
P0.28	Digital I/O	General purpose I/O
AIN4	Analog input	SAADC/COMP/LPCOMP input
GND	Ground	

## 2.3 Block diagram

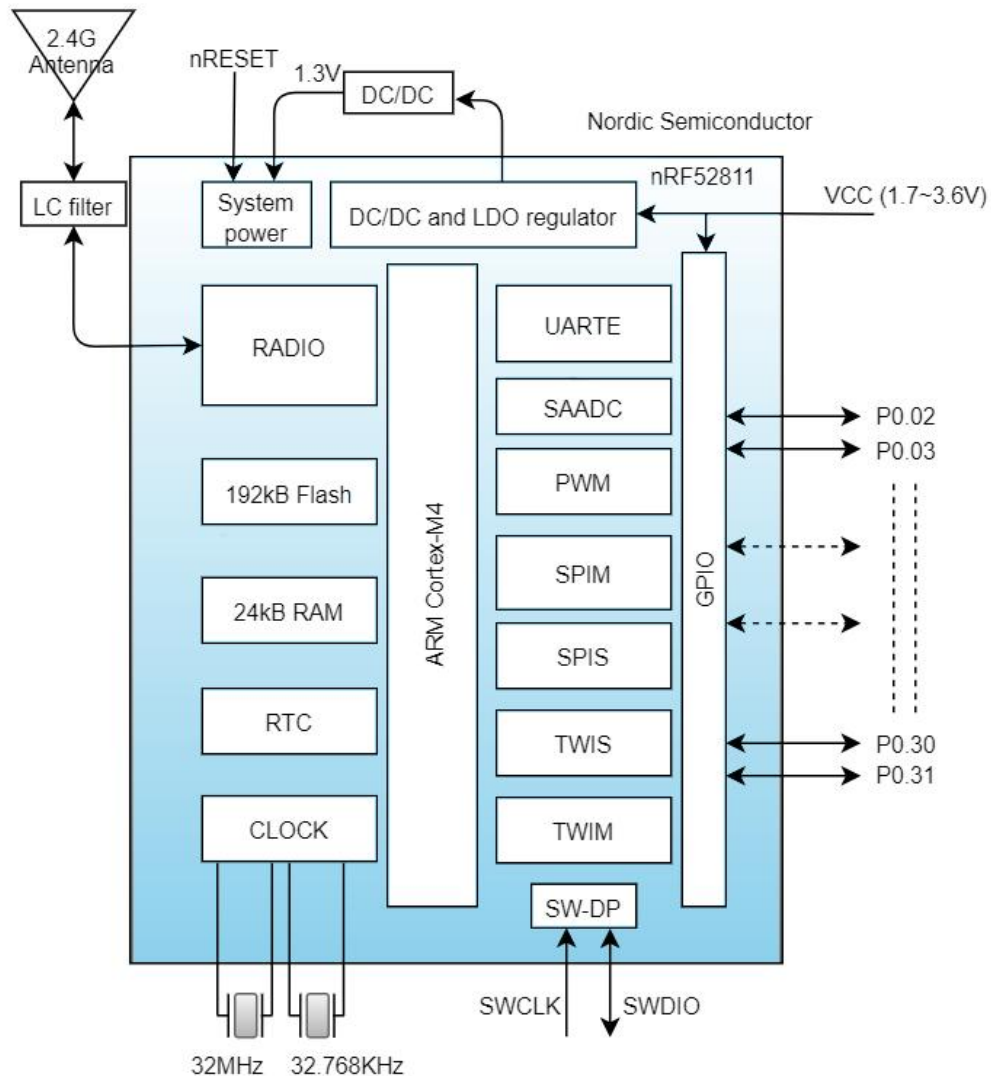



## 2.4 Mechanical Drawing

### 2.4.1 MS50SFB PCB Antenna

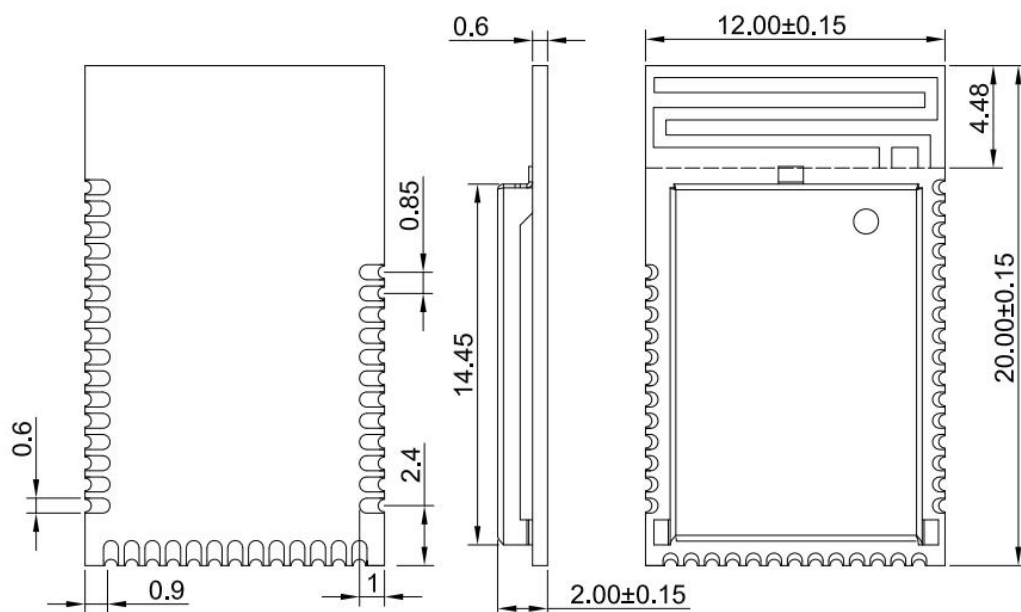

### 2.4.2 MS50SFB chip Antenna

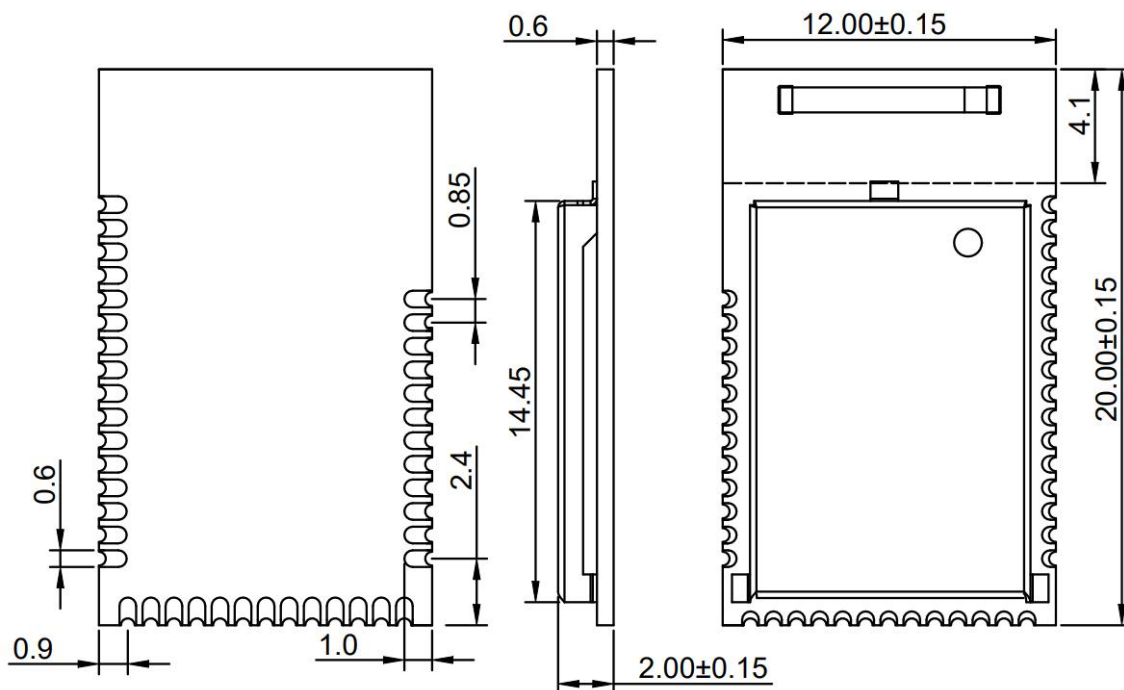

### 2.4.3 MS50SFB u.FL/IPEX connector

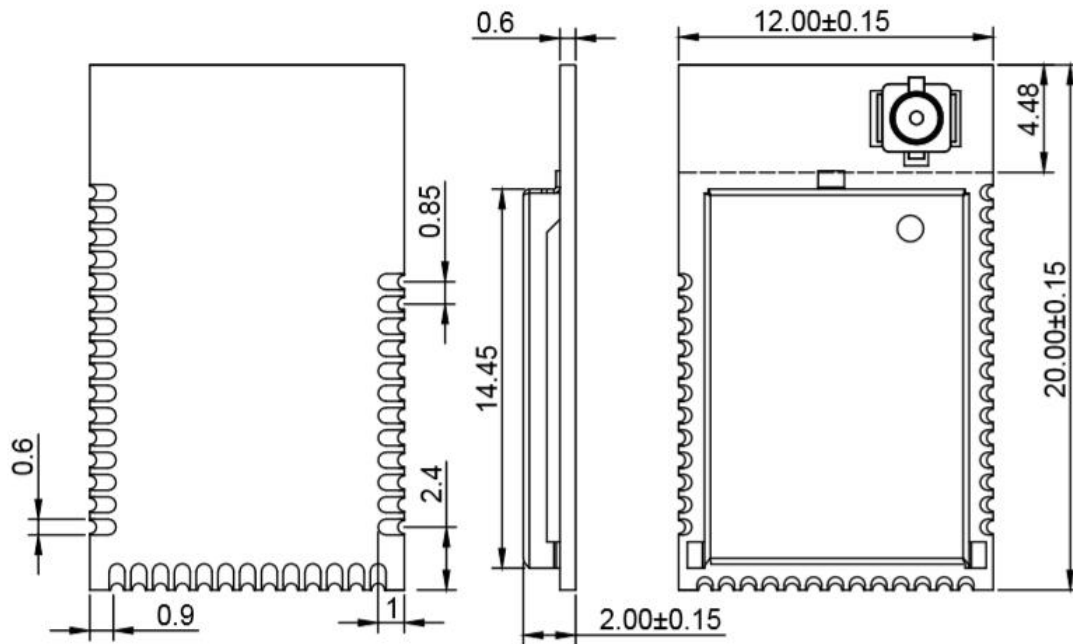

**Important:** Unit: mm Tolerance: +/- 0.1, default  
Recommend solder pad size: 1.7\*0.6mm, solder pad is suggested to extend 0.8mm distance.

### 3 Electrical Specification

The electrical specifications of the module are directly related to the Nordic semiconductor Specifications for the nRF52811 chipset. The below information is only the extract from nRF52811 specification. For more detailed information, please refer to the up-to-date specification of the chipset available on the Nordic semiconductor website.

#### 3.1 Absolute maximum ratings

Note	Min.	Max.	Unit
<b>Supply voltages</b>			
VDD	-0.3	+3.9	V
VSS		0	V
<b>I/O pin voltage</b>			
$V_{I/O}, VDD \leq 3.6\text{ V}$	-0.3	$VDD + 0.3\text{ V}$	V
$V_{I/O}, VDD > 3.6\text{ V}$	-0.3	3.9V	V
<b>Environmental WLCSP package</b>			
Storage temperature	-40	+125	°C
MSL(moisture sensitivity level )		1	
ESD HBM(Human Body Model)		3	kV
ESD HBM Class(Human Body Model Class)		2	
ESD CDM(Charged Device Model)		1	kV
<b>Flash Memory</b>			
Endurance	10 000		write/erase cycles
Retention at 85 °C	10		years

**Important:** Maximum ratings are the extreme limits to which the chip can be exposed for a limited amount of time without permanently damaging it. Exposure to absolute maximum ratings for prolonged periods of time may affect the reliability of the device.

## 3.2 Recommended operating conditions

The operating conditions are the physical parameters that the chip can operate within.

Symbol	Parameter	Notes	Min.	Nom.	Max.	Units
VDD	Supply voltage, independent of DCDC enable		1.7	3.0	3.6	V
T <sub>R,VDD</sub>	Supply rise time (0 V to 1.7 V)				60	ms
TA	Operating temperature		-40	25	85	°C

**Important:** The on-chip power-on reset circuitry may not function properly for rise times longer than the specified maximum.

## 3.3 Electronic characteristic

### 3.3.1 General radio characteristics

Symbol	Description	Min.	Typ.	Max.	Units
f <sub>OP</sub>	Operating frequencies	2360		2500	MHz
f <sub>PLL,CH,SP</sub>	PLL channel spacing		1		MHz
f <sub>DELTA,1M</sub>	Frequency deviation @ 1 Msps		±170		kHz
f <sub>DELTA,BLE,1M</sub>	Frequency deviation @ BLE 1 Msps		±250		kHz
f <sub>DELTA,2M</sub>	Frequency deviation @ 2 Msps		±320		kHz
f <sub>DELTA,BLE,2M</sub>	Frequency deviation @ BLE 2 Msps		±500		kHz
Fsk <sub>BPS</sub>	On-the-air data rate	1000		2000	ksps

### 3.3.2 Radio current consumption (Transmitter)

Symbol	Description	Min.	Typ.	Max.	Units
I <sub>TX,PLUS4dBm,DCDC</sub>	TX only run current(DCDC,3V) <sub>P<sub>RF</sub>=+4 dBm</sub>		7.0		mA
I <sub>TX,PLUS4dBm</sub>	TX only run current <sub>P<sub>RF</sub>=+4 dBm</sub>		15.4		mA
I <sub>TX,0dBm,DCDC</sub>	TX only run current(DCDC,3V) <sub>P<sub>RF</sub>=0 dBm</sub>		4.6		mA

$I_{TX,0dBm}$	TX only run current $P_{RF}=0$ dBm	10.1	mA
$I_{TX,MINUS4dBm,DCDC}$	TX only run current DCDC,3V $P_{RF}=-4$ dBm	3.6	mA
$I_{TX,MINUS4dBm}$	TX only run current $P_{RF}=-4$ dBm	7.8	mA
$I_{TX,MINUS8dBm,DCDC}$	TX only run current DCDC,3V $P_{RF}=-8$ dBm	3.2	mA
$I_{TX,MINUS8dBm}$	TX only run current $P_{RF}=-8$ dBm	6.8	mA
$I_{TX,MINUS12dBm,DCDC}$	TX only run current DCDC,3V $P_{RF}=-12$ dBm	2.9	mA
$I_{TX,MINUS12dBm}$	TX only run current $P_{RF}=-12$ dBm	6.2	mA
$I_{TX,MINUS16dBm,DCDC}$	TX only run current DCDC,3V $P_{RF}=-16$ dBm	2.7	mA
$I_{TX,MINUS16dBm}$	TX only run current $P_{RF}=-16$ dBm	5.7	mA
$I_{TX,MINUS20dBm,DCDC}$	TX only run current DCDC,3V $P_{RF}=-20$ dBm	2.5	mA
$I_{TX,MINUS20dBm}$	TX only run current $P_{RF}=-20$ dBm	5.4	mA
$I_{TX,MINUS40dBm,DCDC}$	TX only run current DCDC,3V $P_{RF}=-40$ dBm	2.1	mA
$I_{TX,MINUS40dBm}$	TX only run current $P_{RF}=-40$ dBm	4.3	mA

### 3.3.3 Radio current consumption (Receiver)

Symbol	Description	Min.	Typ.	Max.	Units
$I_{RX,1M,DCDC}$	RX only run current (DCDC, 3V) 1Mbps / 1Mbps BLE		4.6		mA
$I_{RX,1M}$	RX only run current (LDO, 3 V) 1Mbps / 1Mbps BLE		10.0		mA
$I_{RX,2M,DCDC}$	RX only run current (DCDC, 3V) 2Mbps / 2Mbps BLE		5.2		mA
$I_{RX,2M}$	RX only run current (LDO, 3 V) 2Mbps / 2Mbps BLE		11.2		mA
$I_{START,RX,1M,DCDC}$	RX start-up current (DCDC 3V) 1Mbps/1Mbps BLE		3.5		mA
$I_{START,RX,1M}$	RX start-up current 1Mbps/1Mbps BLE		6.7		mA

### 3.3.4 Transmitter specification

Symbol	Description	Min.	Typ.	Max.	Units
$P_{RF}$	Maximum output power		4.0		dBm
$P_{RFC}$	RF power control range		24		dB
$P_{RFCR}$	RF power accuracy			±4	dB
$P_{RF1,1}$	1st Adjacent Channel Transmit Power 1 MHz (1 Mbps )		-25		dBc
$P_{RF2,1}$	2nd Adjacent Channel Transmit Power 2 MHz (1 Mbps )		-50		dBc
$P_{RF1,2}$	1st Adjacent Channel Transmit Power 2 MHz (2 Mbps)		-25		dBc
$P_{RF2,2}$	2nd Adjacent Channel Transmit Power 4 MHz (2 Mbps)		-50		dBc

### 3.3.5 Receiver operation

Symbol	Description	Min.	Typ.	Max.	Units
$P_{RX,MAX}$	Maximum received signal strength at < 0.1% BER		0		dBm
$P_{SENS,IT,1M}$	Sensitivity, 1Msps nRF mode mode ideal transmitter <sup>1</sup>		-94		dBm
$P_{SENS,IT,2M}$	Sensitivity, 2 Mbps nRF mode ideal transmitter <sup>2</sup>		-91		dBm
$P_{SENS,IT,SP,1M,BLE}$	Sensitivity, 1 Mbps BLE ideal transmitter, packet length $\leq$ 37 bytes BER=1E-3 <sup>3</sup>		-97		dBm
$P_{SENS,IT,LP,1M,BLE}$	Sensitivity, 1 Mbps BLE ideal transmitter, packet length $\geq$ 128 bytes BER=1E-4 <sup>4</sup>		-96		dBm
$P_{SENS,IT,SP,2M,BLE}$	Sensitivity, 2 Mbps BLE ideal transmitter, packet length $\leq$ 37		-94		dBm

<sup>1</sup> Typical sensitivity applies when ADDR0 is used for receiver address correlation. When ADDR[1...7] are used for receiver address correlation, the typical sensitivity for this mode is degraded by 3dB.

<sup>2</sup> Desired signal level at PIN = -67 dBm. One interferer is used, having equal modulation as the desired signal. The input power of the interferer where the sensitivity equals BER = 0.1% is presented.

<sup>3</sup> As defined in the Bluetooth Core Specification v4.0 Volume 6: Core System Package (Low Energy Controller Volume)

<sup>4</sup> Equivalent BER limit < 10E-04

### 3.3.6 RX selectivity

Symbol	Description	Min.	Typ.	Max.	Units
$C/I_{1M,co-channel}$	1Msps mode, Co-Channel interference		9		dBm
$C/I_{1M,-1MHz}$	1 Msps mode, Adjacent (-1 MHz) interference		-2		dBm
$C/I_{1M,+1MHz}$	1 Msps mode, Adjacent (+1 MHz) interference		-10		dBm
$C/I_{1M,-2MHz}$	1 Msps mode, Adjacent (-2 MHz) interference		-19		dBm
$C/I_{1M,+2MHz}$	1 Msps mode, Adjacent (+2 MHz) interference		-42		dBm
$C/I_{1M,-3MHz}$	1 Msps mode, Adjacent (-3 MHz) interference		-38		dBm
$C/I_{1M,+3MHz}$	1 Msps mode, Adjacent (+3 MHz) interference		-48		dB
$C/I_{1M,\pm 6MHz}$	1 Msps mode, Adjacent ( $\geq 6$ MHz) interference		-50		dB
$C/I_{1MBLE,co-channel}$	1 Msps BLE mode, Co-Channel interference		6		dB
$C/I_{1MBLE,-1MHz}$	1 Msps BLE mode, Adjacent (-1 MHz) interference		-2		dB
$C/I_{1MBLE,+1MHz}$	1Msps BLE mode, Adjacent (+1 MHz) interference		-9		dB
$C/I_{1MBLE,-2MHz}$	1Msps BLE mode, Adjacent (-2 MHz) interference		-22		dB
$C/I_{1MBLE,+2MHz}$	1Msps BLE mode, Adjacent (+2 MHz) interference		-46		dB
$C/I_{1MBLE,>3MHz}$	1Msps BLE mode, Adjacent ( $\geq 3$ MHz) interference		-50		dB
$C/I_{1MBLE,image}$	Image frequency Interference -22 dB		-22		dB
$C/I_{1MBLE,image,1MHz}$	Adjacent (1 MHz) interference to in-band image frequency		-35		dB
$C/I_{2M,co-channel}$	2 Msps mode, Co-Channel interference		10		dB
$C/I_{2M,-2MHz}$	2 Msps mode, Adjacent (-2 MHz) interference		6		dB
$C/I_{2M,+2MHz}$	2 Msps mode, Adjacent (+2 MHz) interference		-14		dB
$C/I_{2M,-4MHz}$	2 Msps mode, Adjacent (-4 MHz) interference		-20		dB
$C/I_{2M,+4MHz}$	2 Msps mode, Adjacent (+4 MHz) interference		-44		dB
$C/I_{2M,-6MHz}$	2 Msps mode, Adjacent (-6 MHz) interference		-42		dB
$C/I_{2M,+6MHz}$	2 Msps mode, Adjacent (+6 MHz) interference		-47		dB



$C/I_{2M,\geq 12MHz}$	2 Msps mode, Adjacent ( $\geq 12$ MHz) interference	-52	dB
$C/I_{2MBLE,co-channel}$	2 Msps BLE mode, Co-Channel interference	6	dB
$C/I_{2MBLE,-2MHz}$	2 Mbps BLE mode, Adjacent (-2 MHz) interference	-2	dB
$C/I_{2MBLE,+2MHz}$	2 Mbps BLE mode, Adjacent (+2 MHz) interference	-12	dB
$C/I_{2MBLE,-4MHz}$	2 Mbps BLE mode, Adjacent (-4 MHz) interference	-22	dB
$C/I_{2MBLE,+4MHz}$	2 Msps BLE mode, Adjacent (+4 MHz) interference	-46	dB
$C/I_{2MBLE,\geq 6MHz}$	2 Msps BLE mode, Adjacent ( $\geq 6$ MHz) interference	-50	dB
$C/I_{2MBLE,image}$	Image frequency Interference	-29	dB
$C/I_{2MBLE,image,2MHz}$	Adjacent (2 MHz) interference to in-band image frequency	-44	dB

### 3.3.7 RX intermodulation

Symbol	Description	Min.	Typ.	Max.	Units
$P_{IMD,5TH,1M}$	IMD performance, 1 Mbps, 5th offset channel, packet length $\leq 37$ bytes		-33		dBm
$P_{IMD,5TH,1M,BLE}$	IMD performance, BLE 1 Mbps, 5th offset channel, packet length $\leq 37$ bytes		-30		dBm
$P_{IMD,5TH,2M}$	IMD performance, 2 Mbps, 5th offset channel, packet length $\leq 37$ bytes		-33		dBm
$P_{IMD,5TH,2M,BLE}$	IMD performance, BLE 2 Mbps, 5th offset channel, packet length $\leq 37$ bytes		-31		dBm

### 3.3.8 Radio timing

Symbol	Description	Min.	Typ.	Max.	Units
$T_{TXEN,BLE,1M}$	Time between TXEN task and READY event after channel FREQUENCY configured (1 Mbps BLE and 150 $\mu$ s TIFS)		140		$\mu$ s
$t_{TXEN,FAST,BLE,1M}$	Time between TXEN task and READY event after channel FREQUENCY configured (1 Mbps BLE with fast ramp-up and 150 $\mu$ s TIFS) FREQUENCY configured (Fast Mode)		40		$\mu$ s
$t_{TXDIS,BLE,1M}$	When in TX, delay between DISABLE task and DISABLED event for MODE = Nrf_1Mbit and MODE = Ble_1Mbit		6		$\mu$ s
$t_{RXEN,BLE,1M}$	Time between the RXEN task and READY event after channel FREQUENCY configured (1 Mbps BLE)		140		$\mu$ s
$t_{RXEN,FAST,BLE,1M}$	Time between the RXEN task and READY event after channel FREQUENCY configured (1 Mbps BLE with fast ramp-up)		40		$\mu$ s
$t_{RXDIS,BLE,1M}$	When in RX, delay between DISABLE task and DISABLED event for MODE = Nrf_1Mbit and MODE = Ble_1Mbit		0		$\mu$ s
$t_{TXDIS,BLE,2M}$	When in TX, delay between DISABLE task and DISABLED event for MODE = Nrf_2Mbit and MODE = Ble_2Mbit		4		$\mu$ s
$t_{RXDIS,BLE,2M}$	When in RX, delay between DISABLE task and DISABLED event for MODE = Nrf_2Mbit and MODE = Ble_2Mbit		0		$\mu$ s

### 3.3.9 Received signal strength indicator (RSSI) specifications

Symbol	Description	Min.	Typ.	Max.	Units
$RSSI_{ACC}$	RSSI Accuracy		$\pm 2$		dB
$RSSI_{RESOLUTION}$	RSSI resolution		1		dB
$RSSI_{PERIOD}$	RSSI sampling time from $RSSI\_START$ task		0.25		$\mu$ s
$RSSI_{SETTLE}$	RSSI settling time after signal level change		15		$\mu$ s

# 4 Electrical Schematic

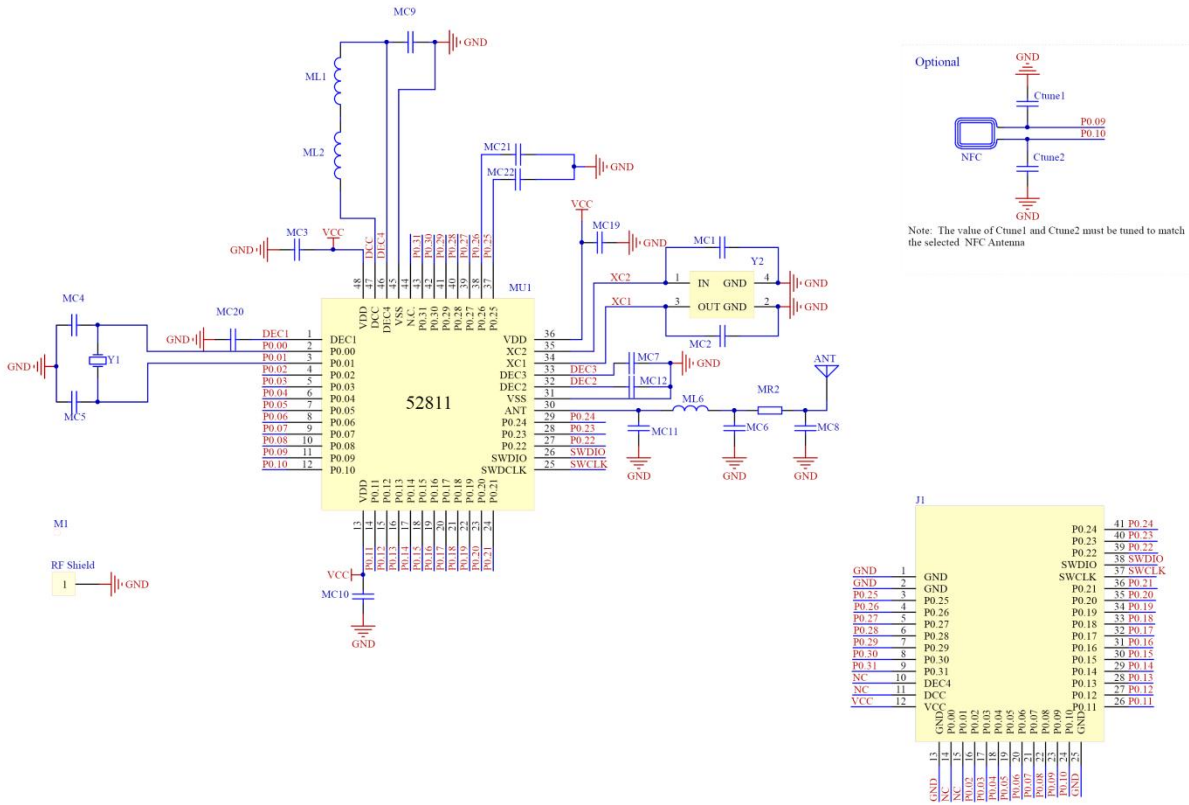

## 5 Package Information

### 5.1 Package dimension

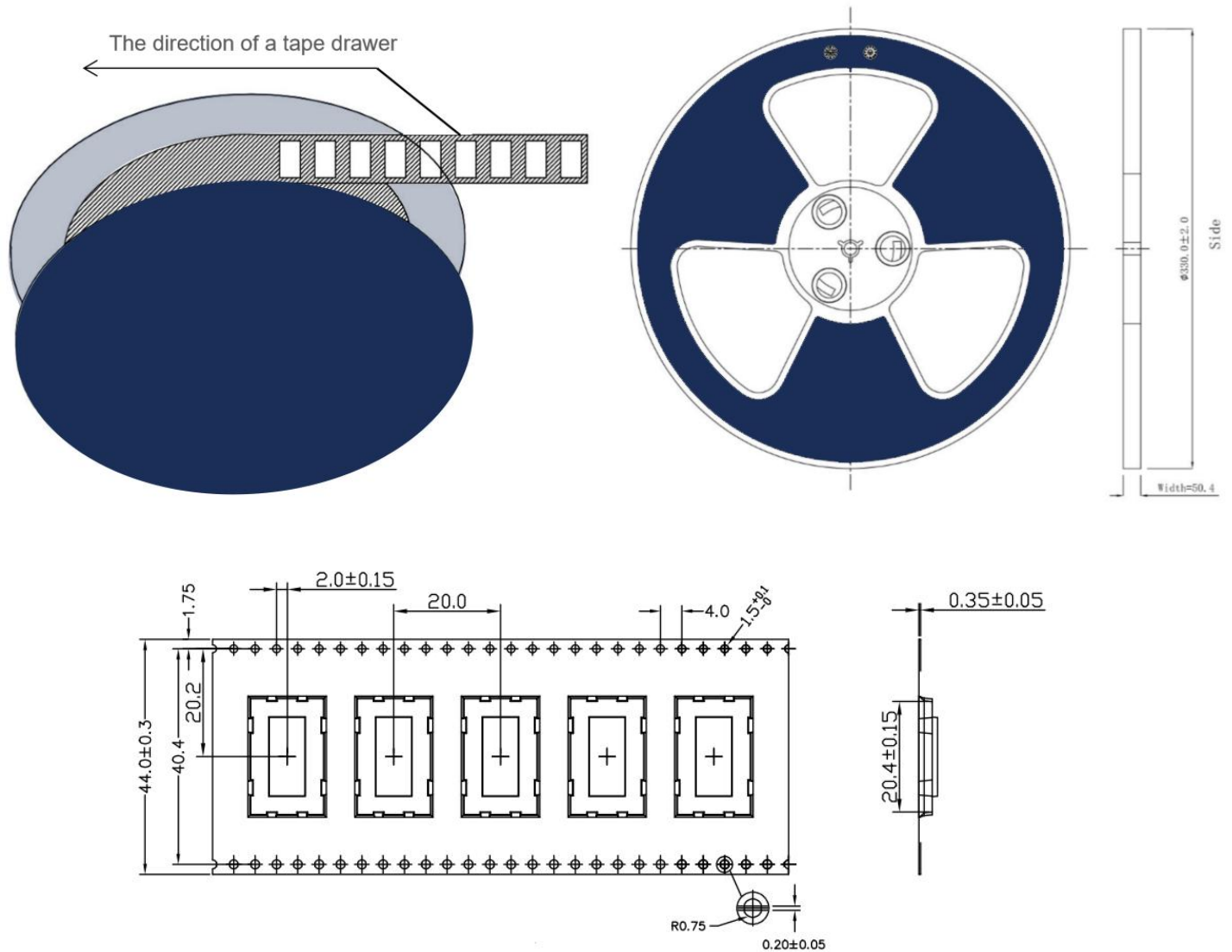

## Details of Package Dimension:

Details	Reel-MS50SFB
Quantity(module)	850PCS
Tape Weight	515g
Single module Weight	0.72g
Gross Weight	1150g
Dimension	W: 44mm T: 0.35mm

## 5.2 Mark on metal shield

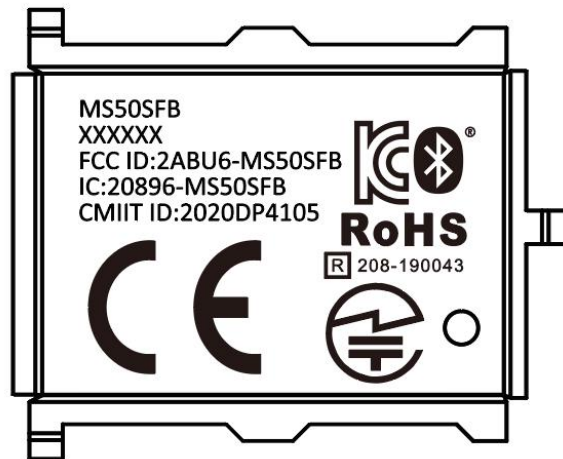

## 6 Reflow and Soldering

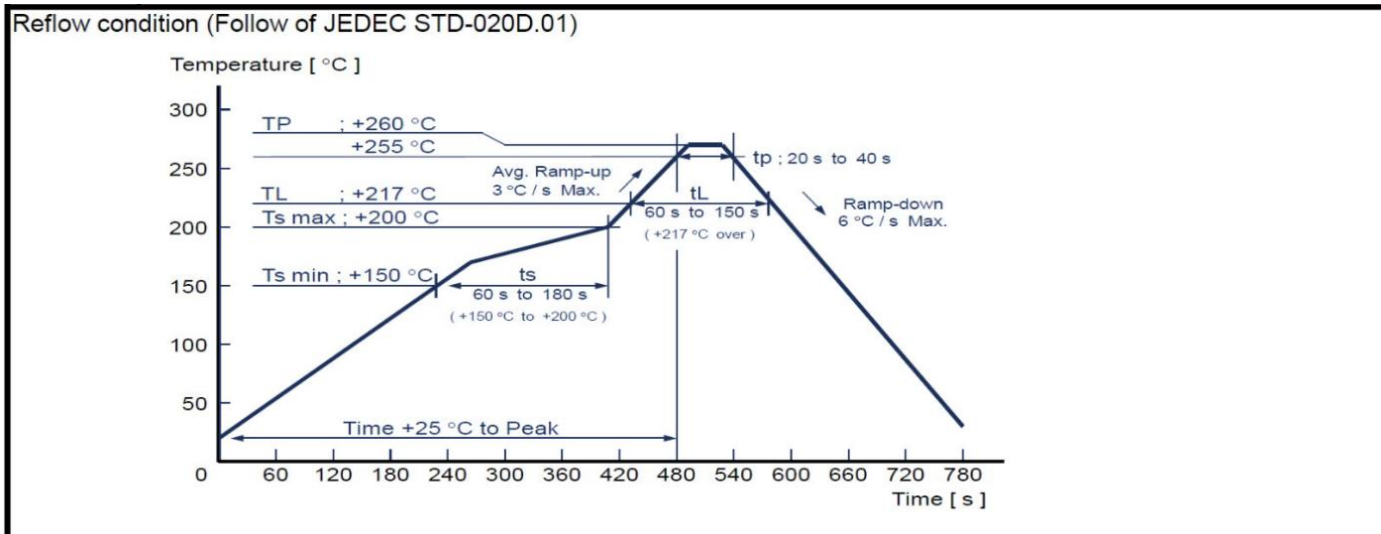

Profile Feature	Sn-Pb Assembly	Pb-Free Assembly
Solder Paste	Sn63/Pb37	Sn96.5/Ag3/Cu0.5
Preheat Temperature min (T <sub>smin</sub> )	100°C	150°C
Preheat Temperature max (T <sub>smax</sub> )	150°C	200°C
Preheat Time (T <sub>smin</sub> to T <sub>smax</sub> )(t <sub>s</sub> )	60-120 sec	60-120 sec
Average ramp-up rate (T <sub>smax</sub> to T <sub>p</sub> )	3°C/second max	3°C/second max
Liquidous Temperature (TL)	183°C	217°C
Time (t <sub>L</sub> )Maintained Above (TL)	60-90 sec	30-90 sec
Peak Temperature (T <sub>p</sub> )	220-235°C	230-250°C
Average ramp-down rate (T <sub>p</sub> to T <sub>smax</sub> )	6°C/second max	6°C/second max
Time 25°C to peak temperature	6 minutes max	8 minutes max

### Important:

- When SMT involves double-sided patch, it is recommended that the module surface be reflowed only once.
- For module SMT, it is recommended to make a partial stepped stencil with a thickness of 0.2mm, and the stencil hole should be extended by 0.8mm size.
- After opening the package, it should be stored in vacuum environment. Module should not be exposed to the air for a long time to prevent moisture and pad oxidation. If there is an interval of 7 to 30 days during SMT process, it is recommended to bake it with reel at 65-70 degrees for 24 hours before using for SMT again.

## 7 Certification

FCC ID:2ABU6-MS50SFB

BQB QDID: 111267

IC: 20896-MS50SFB

TELEC: 208-190043

KC: R-R-miW-MS50SFB

CE,WPC,RCM,Rosh,Reach certified

### 7.1 CE Certification

MS50SFB module is being tested and is expected to be compliant against the EU-Radio Equipment standards. OEM integrator should consult with qualified test house to verify all regulatory requirements have been met for their complete device.

### 7.2 FCC Certification

MS50SFB module is being tested and is expected to be compliant against the Federal Communications Commission standards.

As for the OEM integration:

Only OEM integrator have right to intend this device under the following conditions:

Any other transmitter or antenna must not be co-located with the antenna and transmitter. The module shall be only used with the integral antenna(s) that has been originally tested and certified with this module.

As long as the two conditions below are met, further transmitter testing will not be required.

(1) This device may not cause harmful interference.

(2) This device must accept any interference received, including interference that may cause undesired operation.

However, the OEM integrator shall test their end-product for any additional compliance requirements with this module installed (for example, digital device emission, PC peripheral requirements, etc.).

If these conditions cannot be met (for example certain laptop configuration or co-location with another transmitter), then the FCC authorization for this module in combination with the host equipment is no longer considered valid and the final product shall not use the FCC ID of the module. In these circumstances, the OEM integrator shall be re-evaluating the end product (including the transmitter) and obtaining a separate FCC authorization.

The OEM shall be verifying end product compliance with FCC Part 15, sub-part B limits for unintentional radiators through an accredited test facility.

## 7.3 Full Bluetooth Declaration ID

Minewsemi technologies meet the Bluetooth specification maintained by Bluetooth SIG, and all the product produced by Minewsemi is properly tested and comply with the Bluetooth license agreements.

Minewsemi is one of the associate member of Bluetooth SIG. The requirement of listing products by companies is become the members of the SIG and also pay the listed fees for each product required.

Please Kindly check the below Link to know more info:

<https://www.bluetooth.com/develop-with-bluetooth/qualification-listing>.

The Bluetooth Low Energy modules based on Nordic Semiconductor SoCs are listed as a “End product”.

## 7.4 Canada (IC)

Minew’s modules have been certified for use in Canada under Industry Canada (IC) Radio Standards Specification (RSS) RSS-210 and RSSGen. Modular approval permits the installation of a module in a host device without the need to rectify the device.

As for the labeling & user Information Requirements, MS50SFB is assigned the IC ID number: 20896-MS50SFB.

Labeling Requirements for the Host Device (from Section 3.2.1, RSS-Gen, Issue 3, December 2010): The host device shall be properly labeled to identify the module within the host device.

User Manual Notice for License-Exempt Radio Apparatus (from Section 7.1.3 RSS-Gen, Issue 3, December 2010): User manuals for license-exempt radio apparatus shall contain the following or equivalent notice in a conspicuous location in the user manual or alternatively on the device or both: This device complies with Industry Canada license exempt RSS standard(s).

Operation is subject to the following two conditions:

this device may not cause interference, and (2) this device must accept any interference, including interference that may cause undesired operation of the device.

Transmitter Antenna (from Section 7.1.2 RSS-Gen, Issue 3, December 2010): User manuals for transmitters shall display the following notice in a conspicuous location:

Under Industry Canada regulations, this radio transmitter may only operate using an antenna of a type and maximum (or lesser) gain approved for the transmitter by Industry Canada. To reduce potential radio interference to other users, the antenna type and its gain should be so chosen that the equivalent isotropically radiated power (e.i.r.p.) is not more than that necessary for successful communication.

## 7.5 Japan (TELEC)

The MS50SFB is approved for use in the Japanese market.

## 7.6 KC

The MS50SFB is approved for use in the Korean market.



## 7.7 India(WPC)

The MS50SFB has been tested to comply with the wireless planning & coordination (WPC) Wing of the Ministry of Communications standard. WPC created in 1952, is the National Radio Regulatory Authority responsible for Frequency Spectrum Management, including licensing and caters for the needs of all wireless users (Government and Private) in the country.

It exercises the statutory functions of the Central Government and issues licenses to establish, maintain and operate wireless stations. WPC is divided into major sections like Licensing and Regulation (LR), New Technology Group (NTG) and Standing Advisory Committee on Radio Frequency Allocation (SACFA). SACFA makes the recommendations on major frequency allocation issues, formulation of the frequency allocation plan, making recommendations on the various issues related to International Telecom Union (ITU), to sort out problems referred to the committee by various wireless users, Siting clearance of all wireless installations in the country etc.

## 7.8 RCM

The MS50SFB has been tested to comply with the AS/NZS 4268:2017, Radio equipment and systems –Short range devices – Limits and methods of measurement. It may be used as evidence in obtaining permission to use the Regulatory Compliance Mark (RCM). Information on registration as a Responsible Party, license and labeling requirements may be found at the following websites:

Australia:

<http://www.acma.gov.au/theACMA/radiocommunications-short-range-devices-standard-2004>.

New Zealand: <http://www.rsm.govt.nz/compliance>.

Only Australian-based and New Zealand-based companies who are registered may be granted permission to use the RCM. An Australian-based or New Zealand-based agent or importer may also register as a Responsible Party to use the RCM on behalf of a company not in Australia or New Zealand.

## 7.9 Environmental

### 7.9.1 RoHs

MS50SFB modules are in compliance with Directive 2011/65/EU, 2015/863/EU of the European Parliament and the Council on the restriction of the use of certain hazardous substances in electrical and electronic equipment.

### 7.9.2 Reach

MS50SFB modules listed below do not contain the 191 SVHC (Substance of Very High Concern), as defined by Directive EC/1907/2006 Article according to REACHAnnex XVII.

## 8 Notes & Cautions

We cannot assure that the specification has no errors and omission even though this specification is under collate and check strictly.

This specification is under the protection of laws and regulations of copyright, please do not copy and duplicate at any form, or do not transmit part or full of this specification in any wire and wireless network in any form, or do not edit or translate to any other format, word, code, etc.

### 8.1 Design notes

- It is critical to following the recommendations of this document to ensure the module meets the specifications.
- The module should be placed at the edge of the circuit board as far as possible to keep away from other circuits.
- Antenna should be kept away from other circuits. It can prevent low radiation efficiency and the normal use of other circuits from being affected.
- The landing of components should be appropriate and that is better for reducing the parasitic inductance.
- Please refuse to supply voltage that is not within the range of specification.
- Please make sure the module or its surface may not suffer from the physical shock or extreme stress.

### 8.2 Layout notes

To make sure wireless performance is at its best condition, please layout the MS50SFB module on the carrier board as below instructions and picture.

#### a) Placement of the antenna

The antenna area of module shall lay clearance completely and should not be blocked by the metal. Otherwise it will have effect on antenna performance (As the picture indicated below).

#### b) Placement of top-layer

The placement of top-layer in carrier board shall be lay copper completely to reduce the signal line in carrier board or other interference.

#### c) Clearance

The upper and below area of antenna (including the case) shall have 4mm or more than 4mm clearance to reduce the influences for antenna.

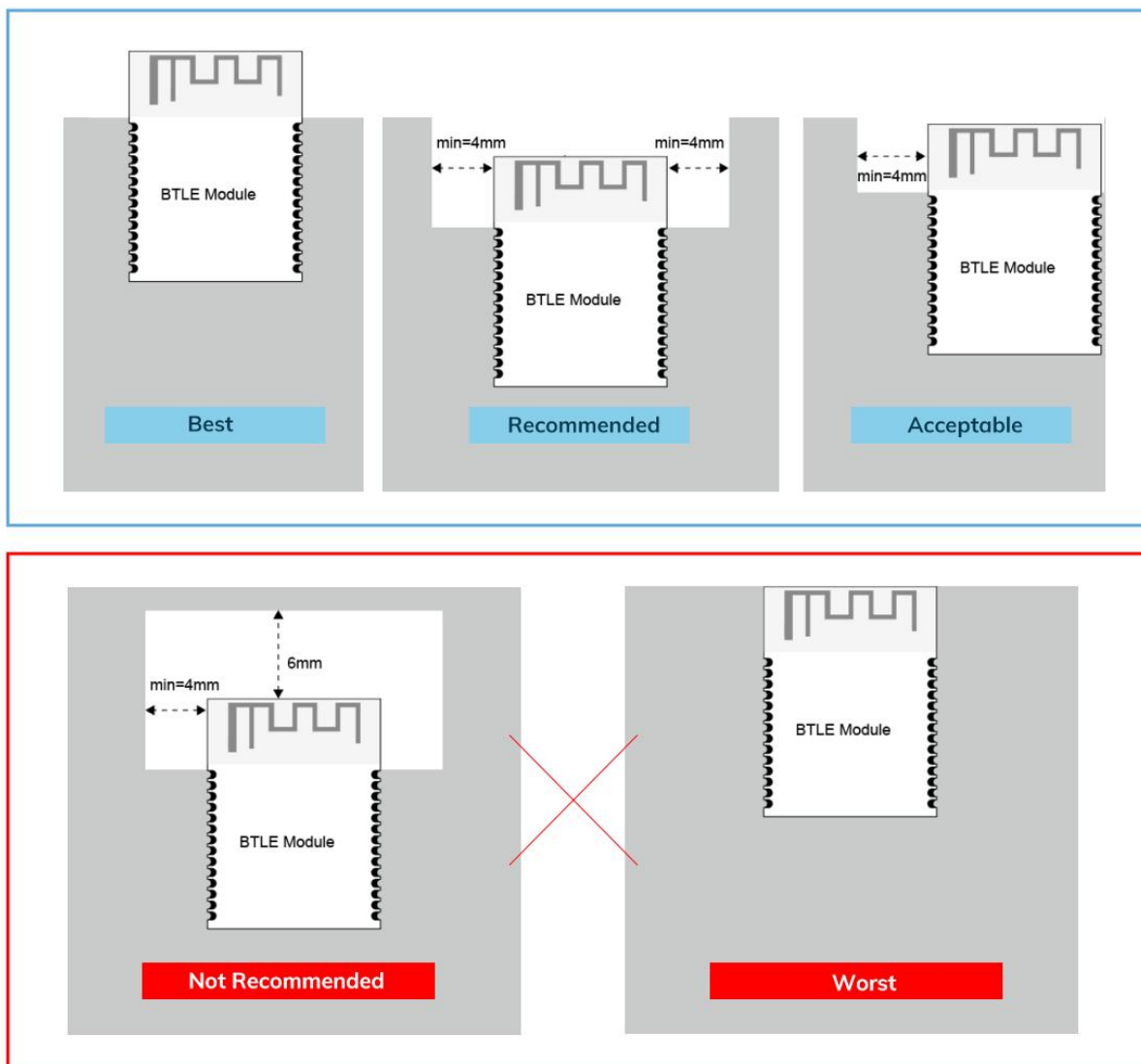

\*The Grey area above is Carrier board.

### 8.3 Installation and soldering

Please do not lay copper under the module antenna. It can prevent the influence of signal radiation and the transmission distance from being affected.

### 8.4 Handling and storage

- a) Due to the fact that CMOS components are included in the module, it is better to eliminate static electricity at any methods when transporting or working with the module. Moreover, it is strongly recommended adding anti-ESD components to circuit design to hinder damage from real-life ESD events. Anti-ESD methods can be also used in mechanical design.



- b) Please store the modules within  $-40^{\circ}\text{C}$  to  $+125^{\circ}\text{C}$  before and after installation and make sure the modules is away from the direct sunlight exposure for a long duration. Modules should be far away from humid and salty air conditions, and any corrosive gasses or substances.
- c) Please not to wash the module. No-Clean Paste is used in production. The metal shield may be oxidized by the washing process and may lead to chemistry reaction with No-Clean Paste. If modules goes through the washing process, functions of the module may not guaranteed.
- d) After opening the package, it should be stored in vacuum environment. Module should not be exposed to the air for a long time to prevent moisture and pad oxidation. If there is an interval of 7 to 30 days during SMT process,

## 8.5 Life support applications

- a) The module is not design for life support device or system and not allowed to be used in destructive devices or system in any direct, or indirect ways. Minewsemi is not responsible for compensation of any losses when applying modules under such application as described above.
- b) Minewsemi shall not responsible for the customer's products or application.

## 9 Disclaimer

The factory has passed the ISO9001 quality management system, ISO14001 environmental management system and OAH18001 occupational health and safety assessment . Each product has been rigorously tested (transmission power test, sensitivity test, power consumption test, stability test, aging test, etc.).

### \* NOTICES:

- The Bluetooth trade mark is owned by the Bluetooth SIG Inc. USA.
- All other trademarks listed herein are owned by their respective owners.
- All specifications are subject to change without notice.
- Please do not use this specification for produce, sell or illegal purpose without MinewSemi's authorization.
- MinewSemi have right to interpret all the items above.

## Revision History

Version	Date	Notes	Contributor (s)	Person of Approve
1.0	2022-03-01	First edition	Eddie	Coral

## COPYRIGHT STATEMENT

This manual and all the contents contained in it are owned by Shenzhen Minewsemi Co., Ltd. and are protected by Chinese laws and applicable international conventions related to copyright laws.

The company has the right to change the content of this manual according to the technological development, and the revised version will not be notified otherwise. Without the written permission and authorization of the company, any individual, company, or organization shall not modify the contents of this manual or use part or all of the contents of this manual in other ways. Violators will be held accountable in accordance with the law.

**MINEWSEMI**

**Tel:** 0086-755-2801 0353

**Email:** minewsemi@minew.com

**URL:** <https://www.minew.com/>

**Address:** 3rd Floor, Building I, Gangzhilong Science Park, Qinglong Road Longhua District, Shenzhen 518109, China

