

Bluetooth PA Module

MS88SFA

Specification V1.0

MinewSemi

- ◆ Subsidiary of Minew Technologies
- ◆ Nordicsemi Strategy Partner
- ◆ Bluetooth SIG Associated Member
- ◆ Fira Alliance Adopter Member

Nordic nRF52840

Bluetooth PA Module

MS88SFA



PCB/IPEX

The MS88SFA is a BLE 5.2 PA/LNA module based on the highly flexible, ultra-low power nRF52840 SoC. Its powerful 32-bit ARM Cortex™ M4F CPU, 1MB flash , 256 kB RAM and integrated 2.4 GH transceiver provide a perfect solution for Bluetooth connectivity. nRF52840 can support protocols such as ANT, BLE, BLE MESH, ZIGBEE and THREAD. Built-in PA/LNA, communication distance up to 600m at 1Mbps rate.

MS88SFA Basic Parameter			
Model	MS88SFA	Antenna	PCB/ IPEX
Chip model	Nordic nRF52840	Module Dimension	23.2×17.4×2mm
Storage Capacity	1M	RAM	256kB
Receiving Sensitivity	-96dBm	Transmission Power	~+20dBm
GPIO	29	Firmware	/
Application area	Smart home , Intelligent wearable device, Consumer electronics, Intelligent medical, Security equipment, Automotive equipment, Sports fitness equipment, Instruments and apparatuses		

INDEX

1 Product introduction	- 4 -
2 Block Diagram.....	- 5 -
3 Electrical Specification	- 6 -
4 Mechanical Drawing.....	- 7 -
5 Pin Description.....	- 8 -
6 Pin definition	- 9 -
7 Electrical Schematic.....	- 10 -
8 PCB Layout	- 11 -
9 Reflow and Soldering.....	- 13 -
10 Package Information	- 14 -
10.1 Package dimension	- 14 -
10.2 Part number description.....	- 15 -
11 Quality Disclaimer.....	- 16 -
12 Revision History	- 16 -
● COPYRIGHT STATEMENT	- 17 -

1 Product introduction

MS88SFA is a BLE5.2 PA/LNA module base on highly flexible and very low power-loss nRF52840 SoC. The strong 32-bit ARM Cortex™ M4F CPU, 1M flash memory, 256kB RAM and integrated 2.4GH transceiver inside it providing wonderful solutions for Bluetooth connecting. nRF52840 is able to support ANT, BLE, BLE MESH, ZIGBEE and THREAD protocols, etc. Communication distance up to 600m under condition of 1Mbps rate and PA/LNA built in .

Feature:

- Bluetooth 5.2
- Built-in PA/LNA
- Power up to Maximum+20dbm
- PCB antenna and IPEX mount optional
- Communication distance up to 600m at 1Mbps rate
- Support ANT, BLE, BLE MESH, ZIGBEE and THREAD protocols, etc.

2 Block Diagram

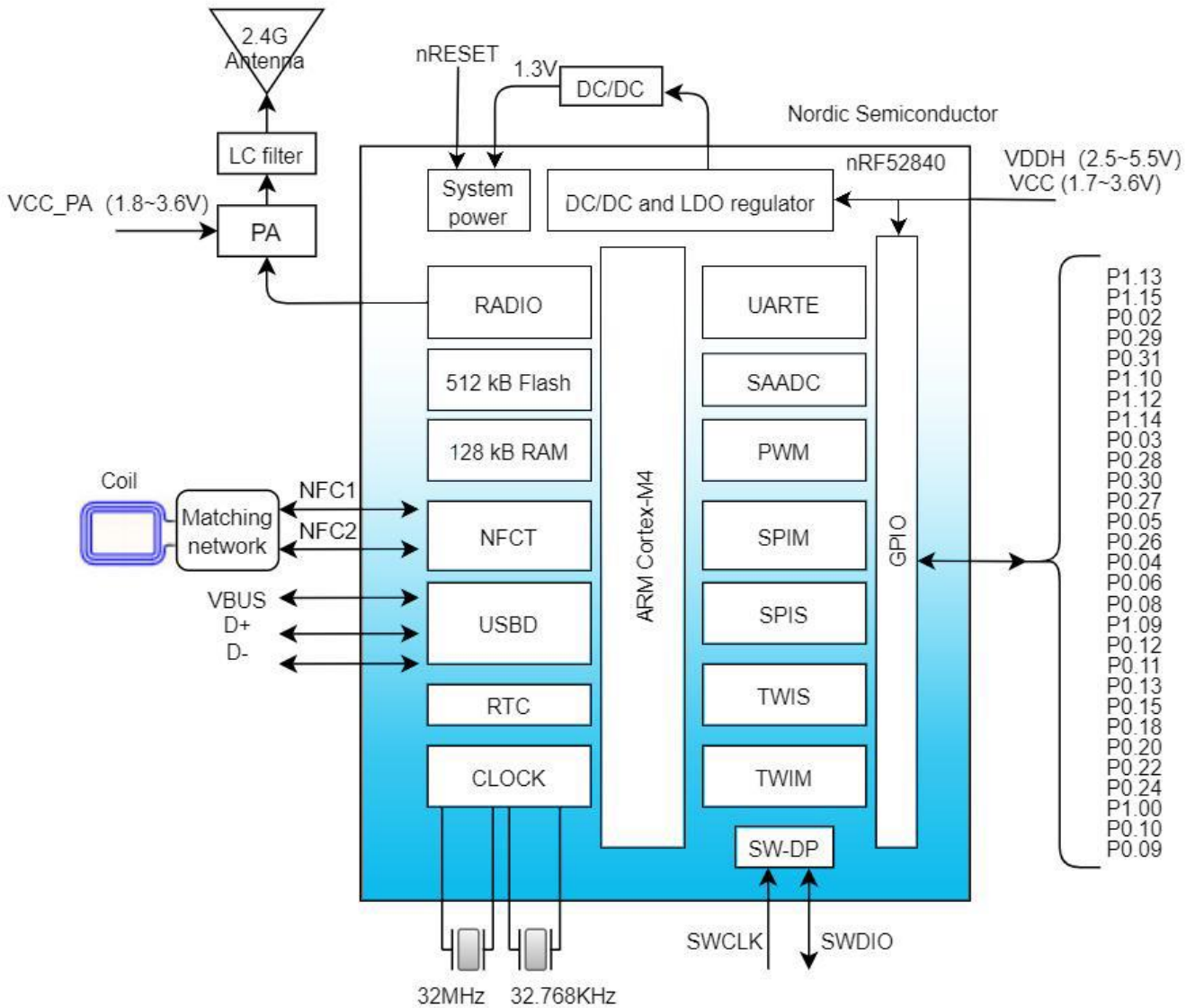

3 Electrical Specification

Parameter	Values	Notes
Working Voltage	1.7V-5.5V	To ensure RF work, supply voltage suggest not lower than 2.3V
Working Temperature	-40°C~+85°C	Storage temperature: -40°C~+125°C
Transmission Power	~ +20dBm	Configurable
Module size	23.2*17.4*2mm	
Quantity of IO port	29	

4 Mechanical Drawing

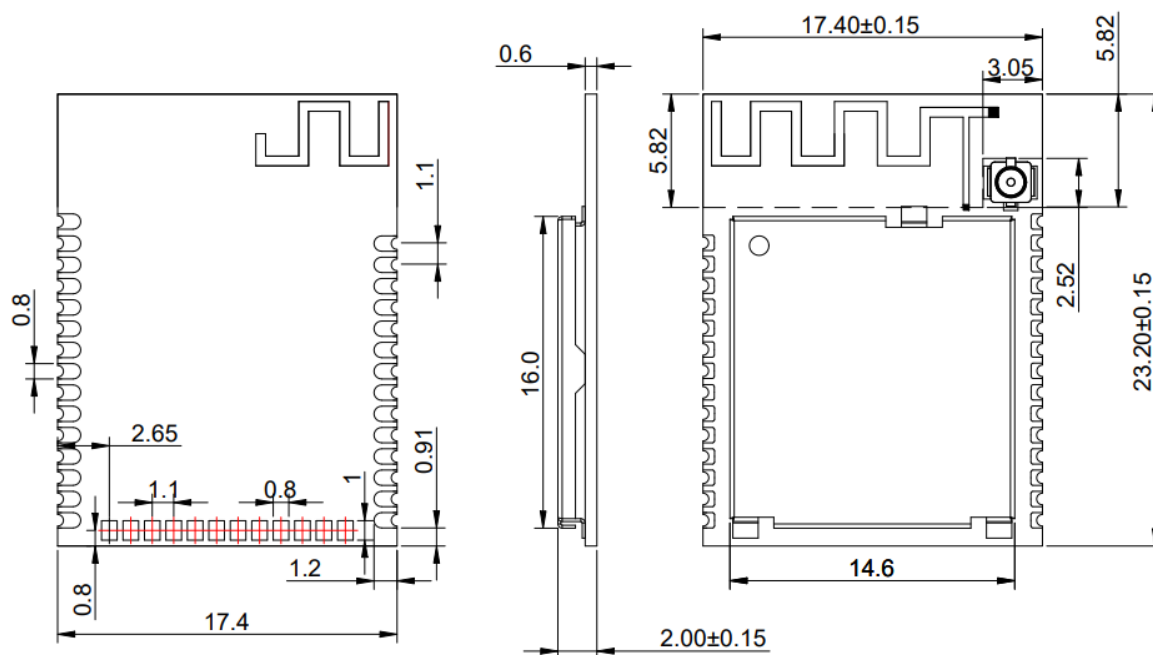

* (Default unit: mm Default tolerance: ±0.1)

Notice: Recommended pad size 1.8*0.8mm, pad extend outward 0.5mm

5 Pin Description

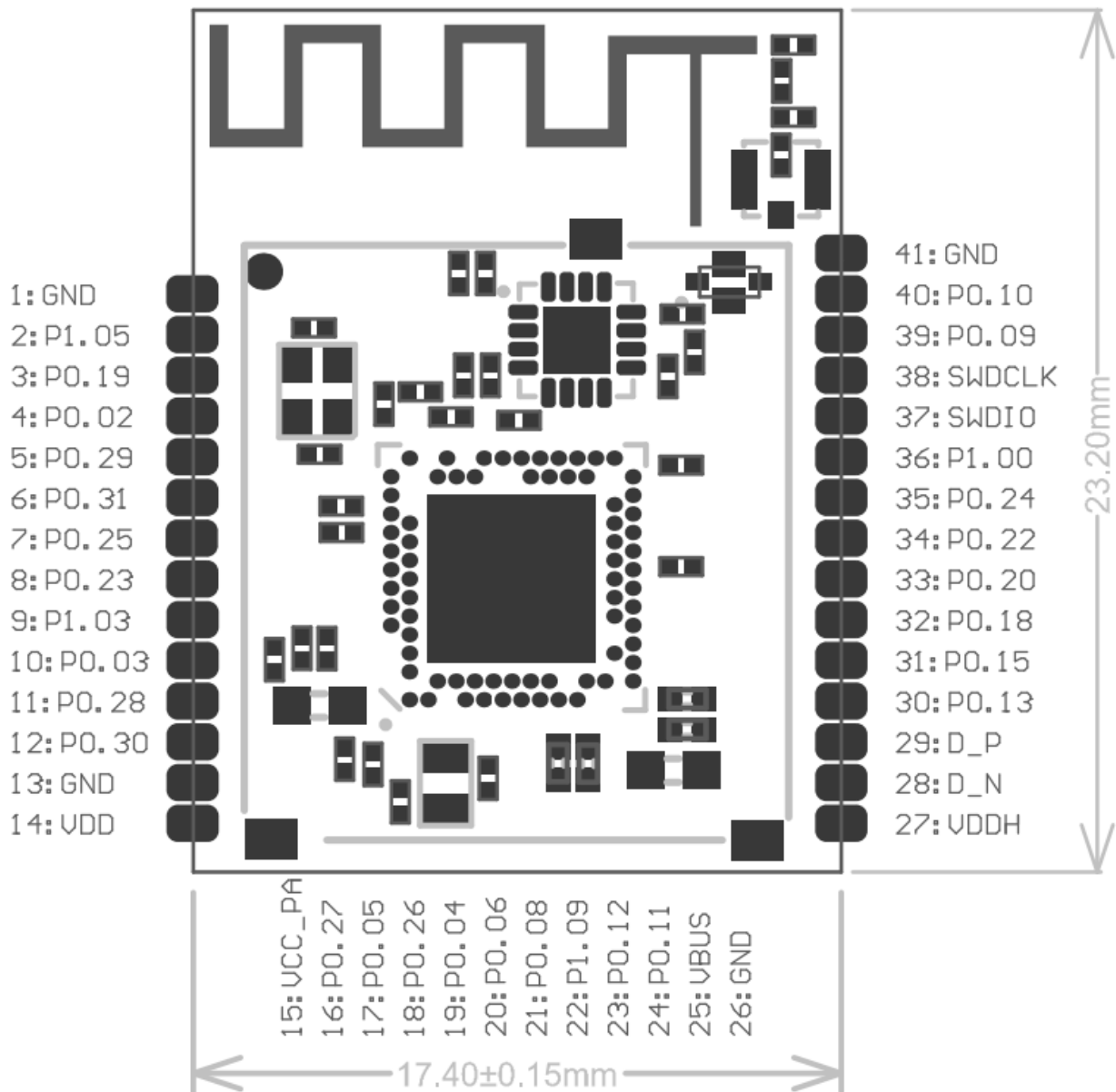

6 Pin definition

Symbol	Type	Description
VDD	Power source	Power supply: 1.7V-3.6V, short-circuit VDD and VDDH to use the pin to supply power
VDDH	Power source	Power supply: 2.5V-5.5V; When supply 5V electricity, use this pin to supply power, not connect VDD pin.
GND	Ground	Ground
SWCLK/SWDIO	Debug	Debug, when debugging only need to connect power supply pin, ground and these 2 pins.
P0.02-P0.31 P1.00-P1.09	I/O	I/O port for general purpose
VBUS	Power source for USB port	5V input current for USB 3.3V modulator Need to supply 5V current and short-circuit this pin with VDDH When use USB port
VCC_PA	PA supply power pin	Must provide electricity of 2.7-3.6V stably, 1.7V-3.6V chip voltage, this pin can be shorted to VDD/VDDH
D+	Digital interface	USB D+
D-	Digital interface	USB D-

7 Electrical Schematic

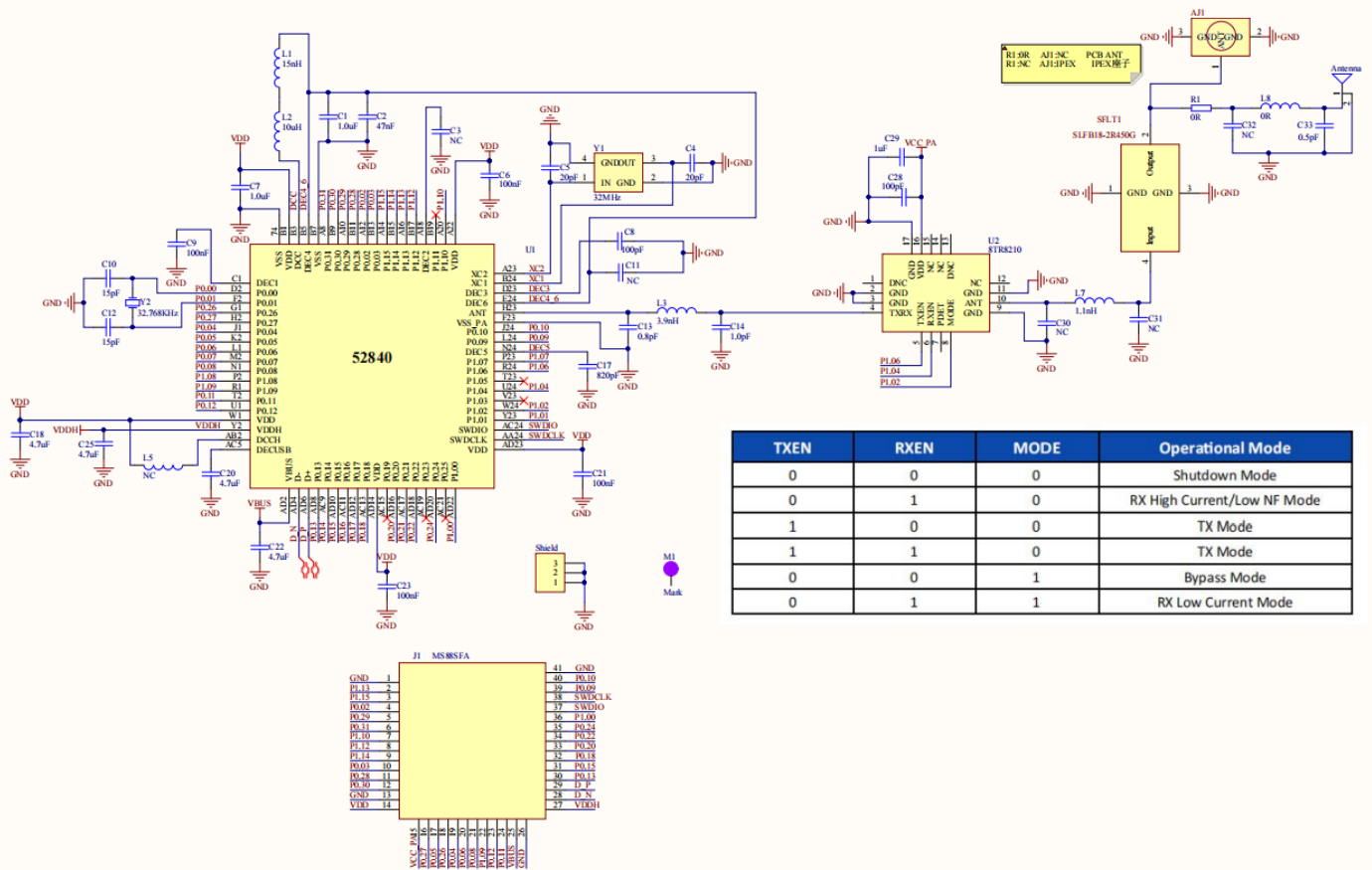

TXEN	RXEN	MODE	Operational Mode
0	0	0	Shutdown Mode
0	1	0	RX High Current/Low NF Mode
1	0	0	TX Mode
1	1	0	TX Mode
0	0	1	Bypass Mode
0	1	1	RX Low Current Mode

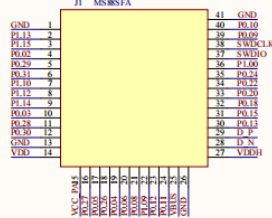

8 PCB Layout

Module antenna area couldn't have GND plane or metal cross line, couldn't place components nearby. It is better to make hollow out or clearance treatment or place it on the edge of PCB board.

Notice: Refer to examples as below, and highly suggest to use the first design and the adjustment of modules antenna design according to the first wiring.



Layout notes:

- 1) Preferred Module antenna area completely clearance and not be prevented by metals, otherwise it will influence antenna's effect (as above DWG. indication).
- 2) Cover the external part of module antenna area with copper as far as possible to reduce the main board's signal cable and other disturbing.
- 3) It is preferred to have a clearance area of 4 square meter or more area around the module antenna (including the shell) to reduce the influence to antenna.
- 4) Device should be grounded well to reduce the parasitic inductance.
- 5) Do not cover copper under module's antenna in order to avoid affect signal radiation or lead to transmission distance affected.
- 6) Antenna should keep far from other circuits to prevent radiation efficiency reduction or affects the normal operation of other lines.
- 7) Module should be placed on edge of circuit board and keep a distance away from other circuits.
- 8) Suggesting to use magnetic beads to insulate module's access power supply.

9 Reflow and Soldering

- 1) Do SMT according to above reflow oven temperature deal curve. Max. Temperature is 260°C. Refer to IPC/JEDEC standard; Peak TEMP<260°C; Times: ≤2 times, suggest only do once reflow soldering on module surface in case of SMT double pad involved. Contact us if special crafts involved.

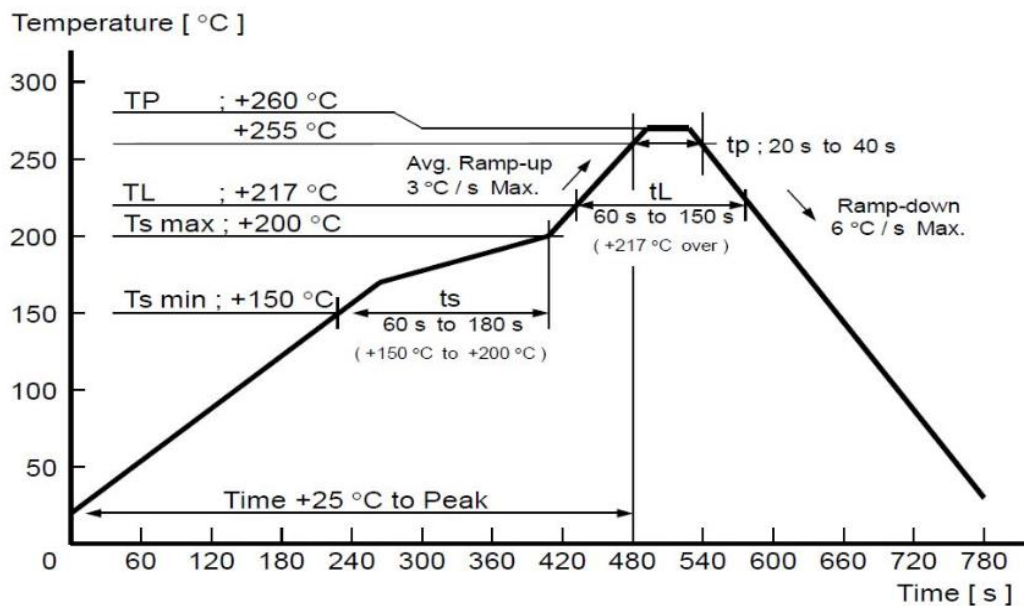

- 2) Suggesting to make 0.2mm thickness of module SMT for partial ladder steel mesh, then make the opening extend 0.8mm
- 3) After unsealing, it cannot be used up at one time, should be vacuumed for storage, couldn't be exposed in the air for long time. Please avoid getting damp and soldering-pan oxidizing. If there are 7 to 30 days interval before using online SMT, suggest to bake at 65-70 °C for 24 hours without disassembling the tape.
- 4) Before using SMT, please adopt ESD protection measure.

10 Package Information

10.1 Package dimension

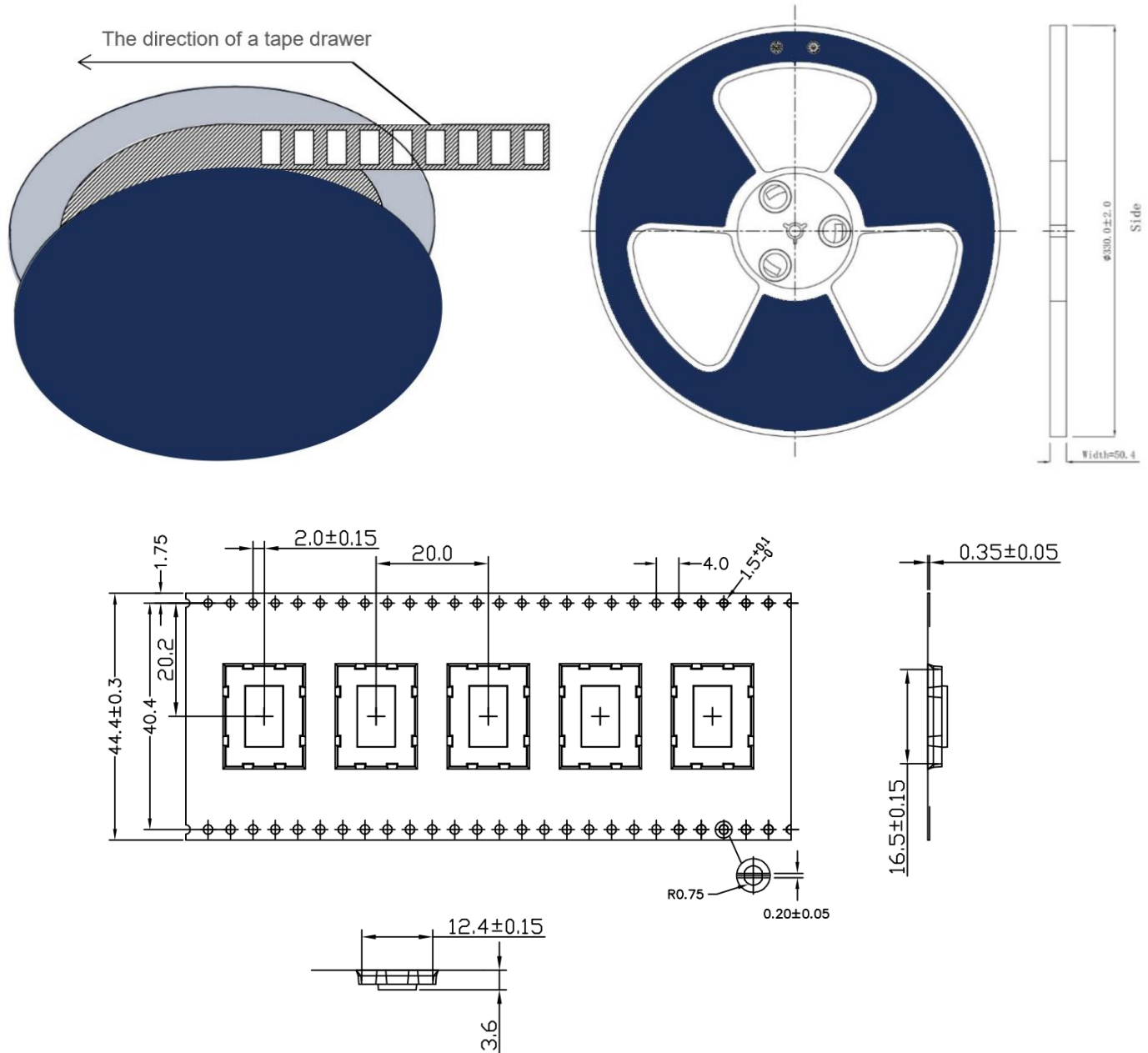

* (Default unit: mm Default tolerance: ±0.1)

Packing detail	Specification	Net weight	Gross weight	Dimension
Quantity	650PCS	560g	1320g	W=44mm, T=0.35mm

* **Note:** Default weight tolerance all are within 10g (except the special notes)

10.2 Part number description

Each module is with different code no. To define whether with 32.768k or not, with on-board antenna or external antenna, the code no. will be marked on the metal shield, description as below:

Part No. in the first line		MS88SFA	Part No. in the second line	8N40AIR
MS88SFA	Module code			
1	Antenna category		1	PCB antenna
			2	Ceramic antenna (Chip antenna)
			3	IPEX connector (1st Generation)
Y	Low-frequency crystal oscillator		Y	With 32.768K Crystal Oscillaor
			N	Without 32.768K Crystal Oscillator
10	SoC		05	m1805, nRF52805
			10	nRF52840
			20	nRF52820
			32	nRF52832
			33	nRF52840
			40	nRF52840, nRF5340
A	SoC Package		A	=AA
			B	=AB
			C	=AC
I	RF Signal Output		I	Internal
			E	External
R	Packing Mode		R	Reel tray
			T	Tray pallet

11 Quality Disclaimer

The factory has passed the ISO9001 quality management system, ISO14001 environmental management system and OAHS18001 occupational health and safety assessment . Each product has been rigorously tested (transmission power test, sensitivity test, power consumption test, stability test, aging test, etc.).

12 Revision History

Version	Change	Contributor	Date	Notes
1.0	First edition	Coral/Ida	2023.2.15	

● COPYRIGHT STATEMENT

This manual and all the contents contained in it are owned by Shenzhen Minewsemi Co., Ltd. and are protected by Chinese laws and applicable international conventions related to copyright laws.

The company has the right to change the content of this manual according to the technological development, and the revised version will not be notified otherwise. Without the written permission and authorization of the company, any individual, company, or organization shall not modify the contents of this manual or use part or all of the contents of this manual in other ways. Violators will be held accountable in accordance with the law.

MINEWSEMI

Tel: 0086-755-2801 0353

Email: minewsemi@minew.com

URL: <https://www.minewsemi.com/>

Address: 3rd Floor, Building I, Gangzhilong Science Park, Qinglong Road Longhua District, Shenzhen 518109, China

