

## Wi-Fi Bluetooth LE Transparent Transmission Module **ME16WS02**



### Datasheet

V 1.0.0



## Version Note

Version	Details	Contributor(s)	Date	Notes
1.0.0	First edit	Vinle, Leo	2024.10.16	

## Part Number

Model	Hardware Code	Product Type Classification
ME16WS02	1N38AI	Hardware code Y, with DC/DC Hardware code N, without DC/DC

Click the icon to view and download the latest product documents electronically.  
[https://en.minewsemi.com/file/ME16WS02-BK7238\\_Datasheet\\_K\\_EN.pdf](https://en.minewsemi.com/file/ME16WS02-BK7238_Datasheet_K_EN.pdf)



# ME16WS02-BK7238

## Multifunctional, cost-effective, supports Bluetooth network configuration, AT command configuration

ME16WS02 is a multifunctional, cost-effective wireless Wi-Fi 4 + BLE 5.2 combination module based on BK7238 SoC. This module supports Wi-Fi 4 + BLE 5.0, equipped with 32-bit MCU, the operating frequency up to 160MHz. In addition, it also has 228KB+2MB SiP Flash large program space 288KB RAM, integrated 2.4GH transceiver, LNA and other powerful supporting resources to provide a perfect solution for 2.4G Wi-Fi/BLE data connection and one-click network configuration. The actual high interference condition test distance can reach 100m.

### FEATURES



2.4G  
WiFi4(802.11b/g/n)+BLE5.2



High operating  
speed up to 160MHz



Supports AP, STA,  
AP+STA Mode



Supports AT  
command configuration



SmartConfig provisioning,  
and airkiss provisioning

### KEY PARAMETER

ME16WS02			
Chip Model	BK7238	Antenna	PCB/ IPEX
Module Size	20.9×15×3mm	GPIO	19
Flash	2MB	RAM	288KB
Receiving Sensitivity	-99dBm	Transmission Power	19dBm
Current(TX)	270mA	Current(RX)	42mA
Firmware	AT Firmware		

### APPLICATION



Smart Home



Consumer Electronics



Automotive Devices



Security Equipment



Intelligent Wearable Device



Smart Agriculture

# INDEX

1 Block Diagram .....	05
2 Electrical Specification .....	05
3 Pin Description .....	06
4 Pin Definition .....	06
5 Mechanical Drawing .....	07
6 Electrical Schematic .....	07
7 Transparent Transmission Function Description .....	08
7.1 Serial Port Setup .....	08
7.2 Wi-Fi Transmission .....	08
7.2.1 Soft-AP Mode Example .....	08
7.2.2 STA Mode Example .....	09
7.2.3 Soft-AP + STA Mixed Mode Example .....	10
7.2.4 Connect the Cloud Server to the MQTT .....	11
8 Power Consumption Description .....	11
8.1 RF Power Consumption .....	11
8.2 Power Management .....	11
9 PCB Layout .....	12
10 Reflow and Soldering .....	12
11 Package Information .....	13
12.Storage Conditions .....	14
13.Handling Conditions .....	14
14.Quality .....	14
15.Copyright Statement .....	15
16.Related Documents .....	15

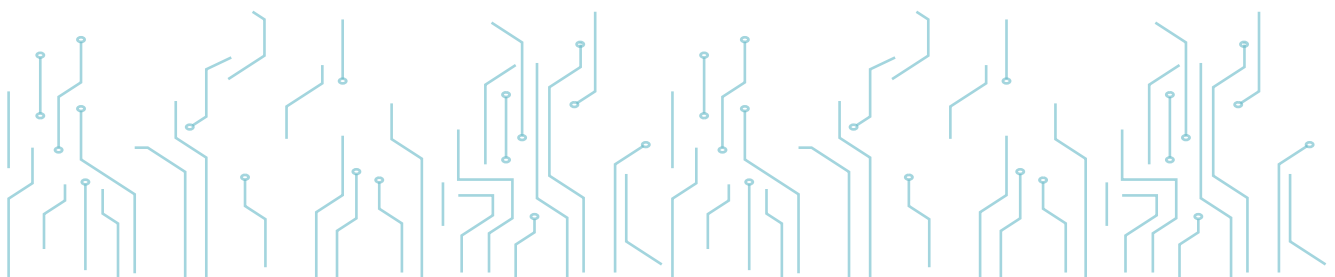

# 1 BLOCK DIAGRAM

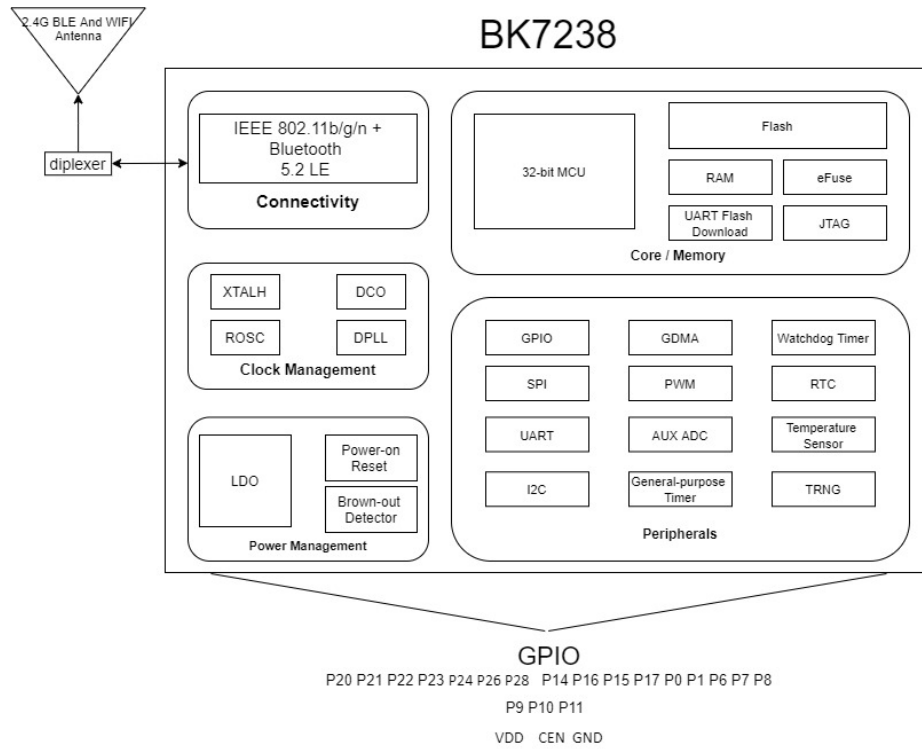

# 2 ELECTRICAL SPECIFICATION

Parameter	Values	Notes
Working Voltage	2.7V-3.6V	To ensure RF work, supply voltage suggest not lower than 3.3V
Working Temperature	-40 C ~+105 C	
Transmission Power	19dBm	Configurable
Receiving Current	42mA	
Transmission Current	270mA	19dBm ,Max Power
Receiving Sensitivitycurrent	-99dBm	

### 3 PIN DESCRIPTION

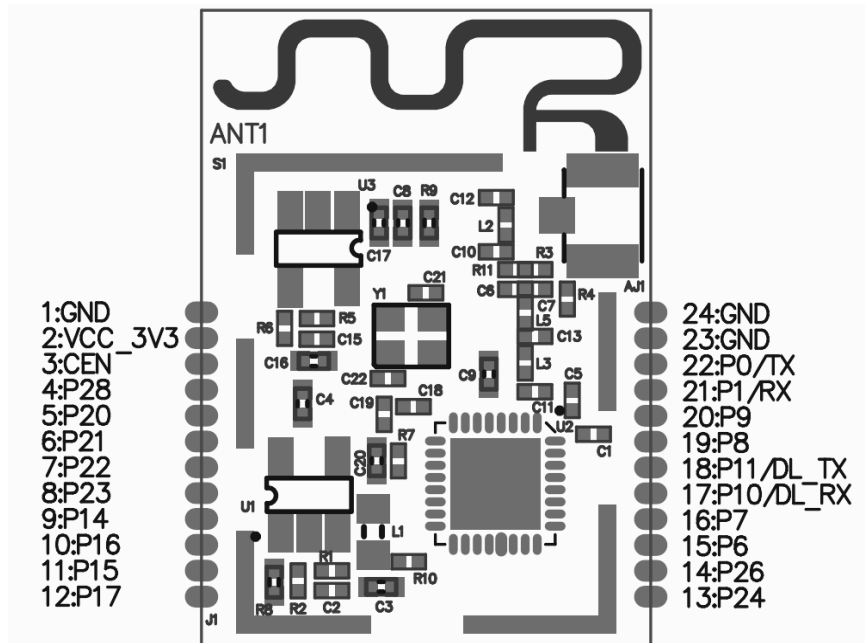

### 4 PIN DEFINITION

Pin Number	Symbol	Definition
GND	Grounded	
VCC	Supply Power	Power supply, 3.0V-3.6V, use this pin to supply 3.3V
CEN	Enable	High level: Chip enable Low level: Chip in disable
P6 - P9	IO	General-purpose IO (GPIO); P21 -P23 P6 -P9: PWM0-PWM3 P14:SPI: SCK P15:SPI: CSN; I2C:SCL P16:SPI: MOSI P17:SPI: MISO; I2C:SDA
P14 - P17	IO	P20:ADC3
P20 - P24	IO	P24:PWM4; I2C:SCL; ADC2
P26, P28	IO	P26:PWM5; I2C:SDA; ADC1 P28:ADC4
P11	Serial port 0 TX	GPIO11: Serial port TXD (Firmware burning and logging)
P10	Serial port 0 RX	GPIO10: Serial port RXD (Firmware burning and logging)
P0	Serial port 1 TX	GPIO0: Serial port TXD;ADC5
P1	Serial port 1 RX	GPIO1: Serial port RXD

# 5 MECHANICAL DRAWING

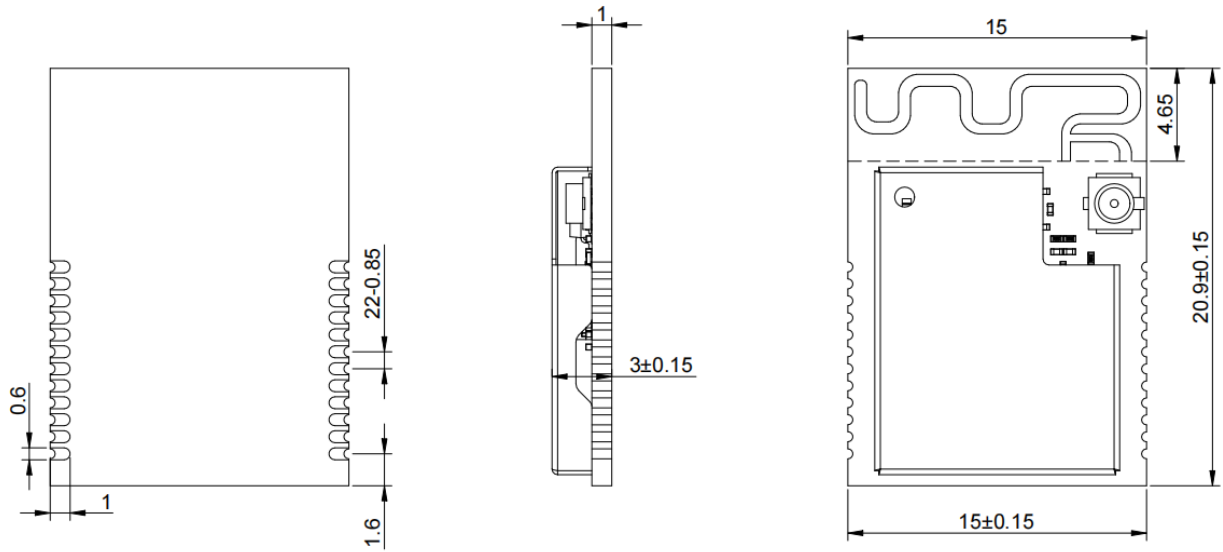

 Default unit: mm Default tolerance: ±0.15

# 6 ELECTRICAL SCHEMATIC

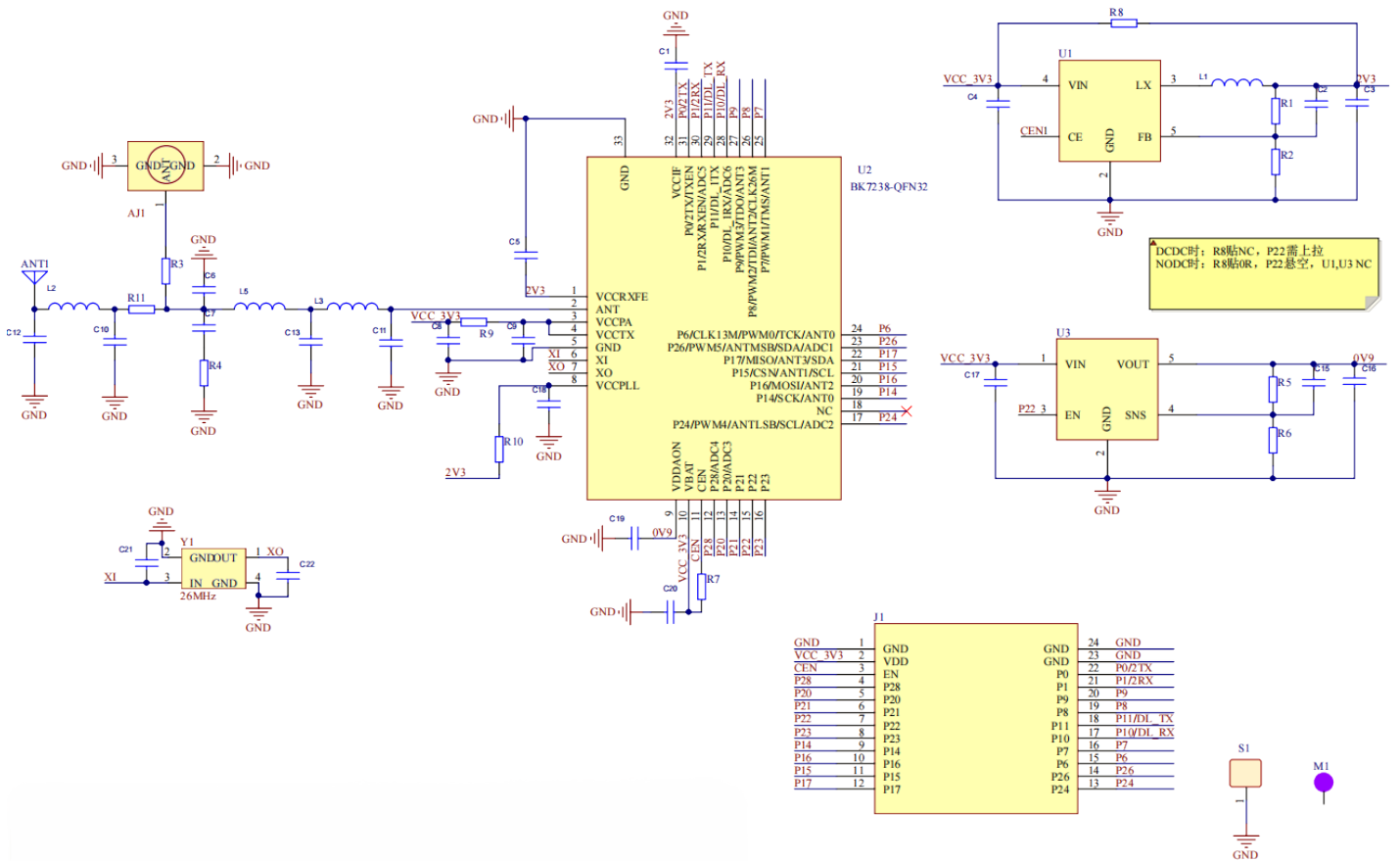

## 7 TRANSPARENT TRANSMISSION FUNCTION DESCRIPTION

The firmware supports both BLE configuration and Wi-Fi transparent transmission. Wi-Fi can be set to either AP or STA mode for data transmission and can connect to various cloud servers such as Alibaba Cloud, Baidu Cloud, and Amazon Cloud. BLE and Wi-Fi can be activated simultaneously, but since BLE is only used for network configuration, the primary data transmission is handled through Wi-Fi and controlled via commands.

To ensure proper module operation, a stable 3.3V power supply is required. When the CEN pin is left floating, the module will wake up, and it defaults to command mode. The transparent transmission firmware features two modes: command mode and transparent transmission mode. In command mode, you can configure the basic parameters, BLE parameters, and Wi-Fi parameters of the module via AT commands. For details, please refer to the "ME16WS02-AT User Guide."

### 7.1 Serial Port Setup

Baud rate: 115200

Data bits: 8

Stop bits: 1

Serial port parity bit: None

Flow type: None

Send line feed settings:

CR&LF(\r\n)

Send setting: ASCII

Receive setting: ASCII

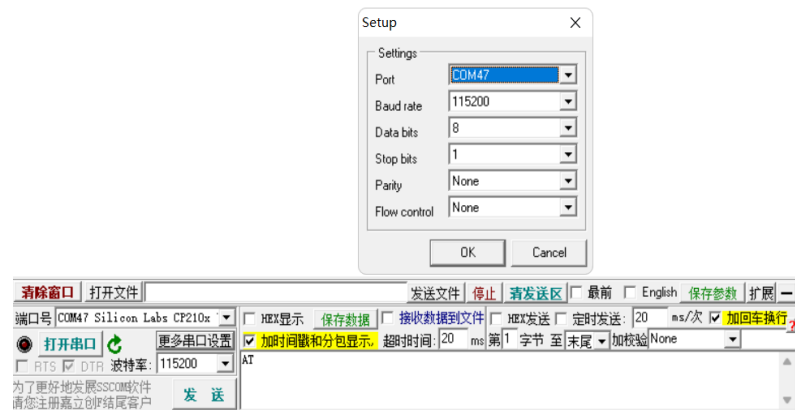

### 7.2 WI-FI Transmission

Wi-Fi can be set to STA mode or Soft-AP mode, or you can use a combination of the two. In the default firmware, to reduce the power consumption of the command usage process, the Wi-Fi is turned on in AP mode by default, and you can directly search for SSIDs starting with bk. In order to reduce power consumption during the use of commands, the radio frequency function of BLE is turned off, so before using BLE normally, you need to turn it on in command mode. For more detailed Wi-Fi command descriptions, please refer to the Wi-Fi command set description in the "ME16WS02-AT User Guide" file.

#### 7.2.1 Soft-AP Mode Example

Soft-AP mode can be colloquially referred to as a base station, which other devices can connect to through the outgoing Wi-Fi. Through a simple module as Soft-AP in UDP transmission UART Wi-Fi transmission function example, to illustrate the basic usage of module AP mode. The sequence and response of serial port instruction are as follows:

① AT+CWMODE? // Check Wi-Fi Mode

Return: OK

② AT+CWMODE=2

//turn on the RF function of Wi-Fi

Return: OK

//set the Wi-Fi Mode to Soft-AP mode

③ AT + CWSAP = "bk7238\_softAP", "1234567890", 5,3 //set Wi-Fi name and password in AP mode

Return: OK

The module establishes the UDP transmission of the fixed-end IP address and the port corresponding to the PC, and the remote IP address is 192.168. 19.100, the remote port is 8080, the local port is 2233, and Open the network debugging assistant and set UDP.



④ AT+CIPSTART=1,"udp","192.168.19.100",8080,2233,"192.168.19.1"

Return: OK

⑤ AT+CIPAP? //query module for IP Gateway Information

Return: + CIPAP: IP: "192.168.19.1,255.255.255.0,192.168.19.1

OK

At this time the module has generated a Wi-Fi named bk7238, now you can use the PC side to connect the AP, connect successfully, use the serial network data debugger, port selection UDP, create a UDP service transport. Local IP address, select 192.168.19.100, port written to 8080, remote IP address queried for ⑤ instruction gateway address 192.0.168.19.1, the port is ④ instructions to set the module port 2233, and finally click on the connection can be.



⑥ AT+CIPMODE = 1 //entering UART Wi-Fi transmit-receive mode

Return: OK

After entering the pass-through receiving mode, the PC can carry out Wi-Fi transmission with the module, but only in one direction. Now the module is in command mode and can receive Wi-Fi pass-through data sent from the PC.

⑦ AT+CIPSEND//enter Wi-Fi transmission mode to receive and send data

Return: OK

After the input of the instruction, you can achieve two-way through the function of the serial input of all data are through the data, if you want to exit the transmission mode, in the serial input + + + (no carriage return line wrap) can enter the normal instruction mode.

When you exit transmission mode with + + + , you are back to Passthrough receive mode, and the TCP connection is still valid. You can resume the Pass-through transmission mode by using the AT + CIPSEND command. Exit UART Wi-Fi Passthrough receive mode using the command: AT + CIPMODE = 0 and close TCP connection command: AT + CIPCLOSE.

## 7.2.2 STA Mode Example

In simple terms, STA mode allows the module to connect to a hotspot generated by a router or a mobile phone. To illustrate the basic use of the module in STA mode, an example of using the module as a TCP client in STA mode to achieve UART Wi-Fi transparent transmission is provided. The sequence of serial commands and the corresponding responses are as follows:

① AT+CWMODE? //Check Wi-Fi Mode

Return: OK

② AT+CWMODE=1 //Set Wi-Fi Mode to STA mode

Return: OK

③ AT+CWJAP="MinewSemi-1", "MinewSemi123" //name and password to connect to other device hotspots.

Return: Wi-Fi CONNECTED

Wi-Fi GOT IP OK

The SSID and password you entered may be different from the above command. Please use your device SSID and password.

④ AT + CIPSTA? //query the IP address of the device

Return: + CIPSTA: IP: "172.16.1.193"

+CIPSTA:gateway:"172.16.0.1"

+CIPSTA:netmask:"255.255.254.0"

OK

Your query results may differ from the above returns

Then connect to the same hotspot as the device on the PC, use the serial port network data debugger on the PC, create a TCP server, select the local IP address 172.16.0.18, port 8080, and listen.



The module, acting as a client, connects to a TCP server via a TCP connection. The server's IP address is the local IP address set by the debugger, which is 172.16.1.216, and the port is 8080. The connection can be established using appropriate commands.

⑤ AT+CIPSTART="TCP","172.16.0.18",8080

Return: Connect OK

⑥ AT+CIPMODE=1 //enter UART Wi-Fi transparent transmission mode

Return: OK

At this point, the module enters both transparent transmission and command mode, allowing command input and TCP server data reception simultaneously.

⑦ AT+CIPSEND

Return: OK >

After entering this command, the bidirectional transparent transmission function is enabled. All data input through the serial port is transmitted transparently. To exit the transparent transmission state, input +++ (without pressing Enter or adding a newline), and the module will return to command mode.

After exiting the transparent transmission mode with +++, the module returns to transparent reception mode, and the TCP connection remains active. You can use the AT+CIPSEND command to resume transparent transmission mode. To exit UART Wi-Fi transparent reception mode, use the command AT+CIPMODE=0, and to close the TCP connection, use the AT+CIPCLOSE command.

### 7.2.3 Soft-AP + STA Mixed Mode Example

The Soft-AP+STA hybrid mode allows the module to be connected by other devices while simultaneously connecting to another device's hotspot. However, in this mode, Wi-Fi transparent transmission cannot occur simultaneously with both ends. The module can switch between connecting to different clients or servers at different times to perform the transparent transmission function. Here's a simple explanation of this mode with a basic hybrid example. The sequence of serial commands and their corresponding responses are as follows:

① AT+CWMODE? //Check Wi-Fi Mode

Return: OK

② AT+CWMODE=3 //Set Wi-Fi Mode to mixed mode

Return: OK

③ AT+CWSAP="bk7238", "1234567890", 5,3//set Wi-Fi name and password in AP mode

Return: OK

④ AT+CWJAP="bk7238", "1234567890"//name and password to connect to other device hotspots

Return: Wi-Fi CONNECTED

Wi-Fi GOT IP

OK

After completing the above commands, the module's Wi-Fi is enabled, allowing it to be connected by other devices while also connecting to another device's Wi-Fi hotspot. You can establish a connection for transparent transmission using the single-mode transparent transmission example mentioned earlier, so it won't be repeated here. However, it is important to note that during a TCP client transparent transmission, no other transparent transmission methods can be performed simultaneously. You must disconnect the TCP connection in command mode using the AT+CIPCLOSE command. This command closes the TCP/UDP/SSL connection in either single or multiple connection modes.

For more detailed examples of TCP-IP usage, please refer to the command examples and AT command set sections of the "ME16WS02-AT User Guide."

### 7.2.4 Connect the Cloud Server to the MQTT

The ME16WS02 module can communicate with cloud servers such as Alibaba Cloud, Baidu Cloud, Tencent Cloud, and Amazon Cloud. The specific communication steps are detailed in the corresponding cloud connection documentation. For MQTT communication between the ME16WS02 and PC, Android, or iOS clients, please refer to the respective client-MQTT communication test documentation. Feel free to contact us to request these documents.

## 8 POWER CONSUMPTION DESCRIPTION

### 8.1 RF Power Consumption

The following power consumption figures are based on 3.3 V power supply, 25 °C ambient temperature, and test results done at the RF interface.

Operating Mode		Operating Status	Type Value (mA)
RF Mode	TX	11 Mbps DSSS @ 17 dBm	270mA
		54 Mbps OFDM @ 15 dBm	230mA
		MCS7, HT20 @ 14 dBm	220mA
	RX	11 Mbps DSSS	40mA
		54 Mbps OFDM	42mA
		MCS7, HT20	42mA

### 8.2 Power Management

Operating Mode	Operating Status	Type Value (mA)
Light-sleep	CPU is powered off; Host, MAC, RTC timer, external interrupt can wake up the chip; Wi-Fi or BLE to stay connected.	41.32µA (GPIO wake up) 503.08µA (RTC wake up)
Deep-sleep	RTC timer + RTC memory The RTC clock timer or RTC GPIO can wake up the chip.	47.71µA

## 9 PCB LAYOUT

Module antenna area couldn't have GND plane or metal cross line, couldn't place components nearby. It is better to make hollow out or clearance treatment or place it on the edge of PCB board.

 Refer to examples as below, and highly suggest to use the first design and the adjustment of modules antenna design according to the first wiring.

### Layout Notes :

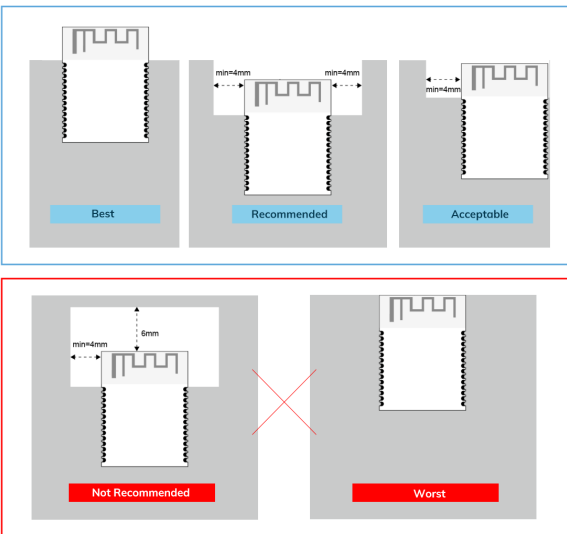

- 1) Preferred Module antenna area completely clearance and not be prevented by metals, otherwise it will influence antenna's effect (as above DWG. indication).
- 2) Cover the external part of module antenna area with copper as far as possible to reduce the main board's signal cable and other disturbing.
- 3) It is preferred to have a clearance area of 4 square meter or more area around the module antenna (including the shell) to reduce the influence to antenna.
- 4) Device should be grounded well to reduce the parasitic inductance.
- 5) Do not cover copper under module's antenna in order to avoid affect signal radiation or lead to transmission distance affected.
- 6) Antenna should keep far from other circuits to prevent radiation efficiency reduction or affects the normal operation of other lines.
- 7) Module should be placed on edge of circuit board and keep a distance away from other circuits.
- 8) Suggesting to use magnetic beads to insulate module's access power supply.

## 10 REFLOW AND SOLDERING

1) Do SMT according to above reflow oven temperature deal curve. Max. Temperature is 260°C; Refer to IPC/JEDEC standard; Peak TEMP<260°C; Times: ≤2 times, suggest only do once reflow soldering on module surface in case of SMT double pad involved. Contact us if special crafts involved.

- 2) Suggesting to make 0.2mm thickness of module SMT for partial ladder steel mesh, then make the opening extend 0.8mm
- 3) After unsealing, it cannot be used up at one time, should be vacuumed for storage, couldn't be exposed in the air for long time. Please avoid getting damp and soldering-pan oxidizing. If there are 7 to 30 days interval before using online SMT, suggest to bake at 65-70 °C for 24 hours without disassembling the tape.
- 4) Before using SMT, please adopt ESD protection measure.

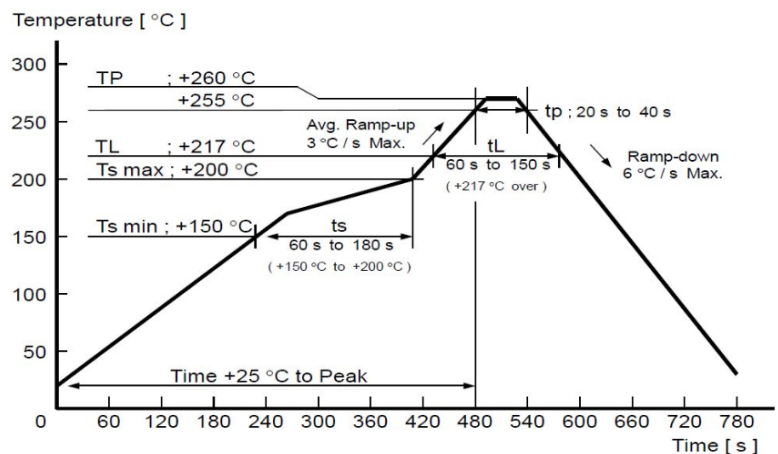



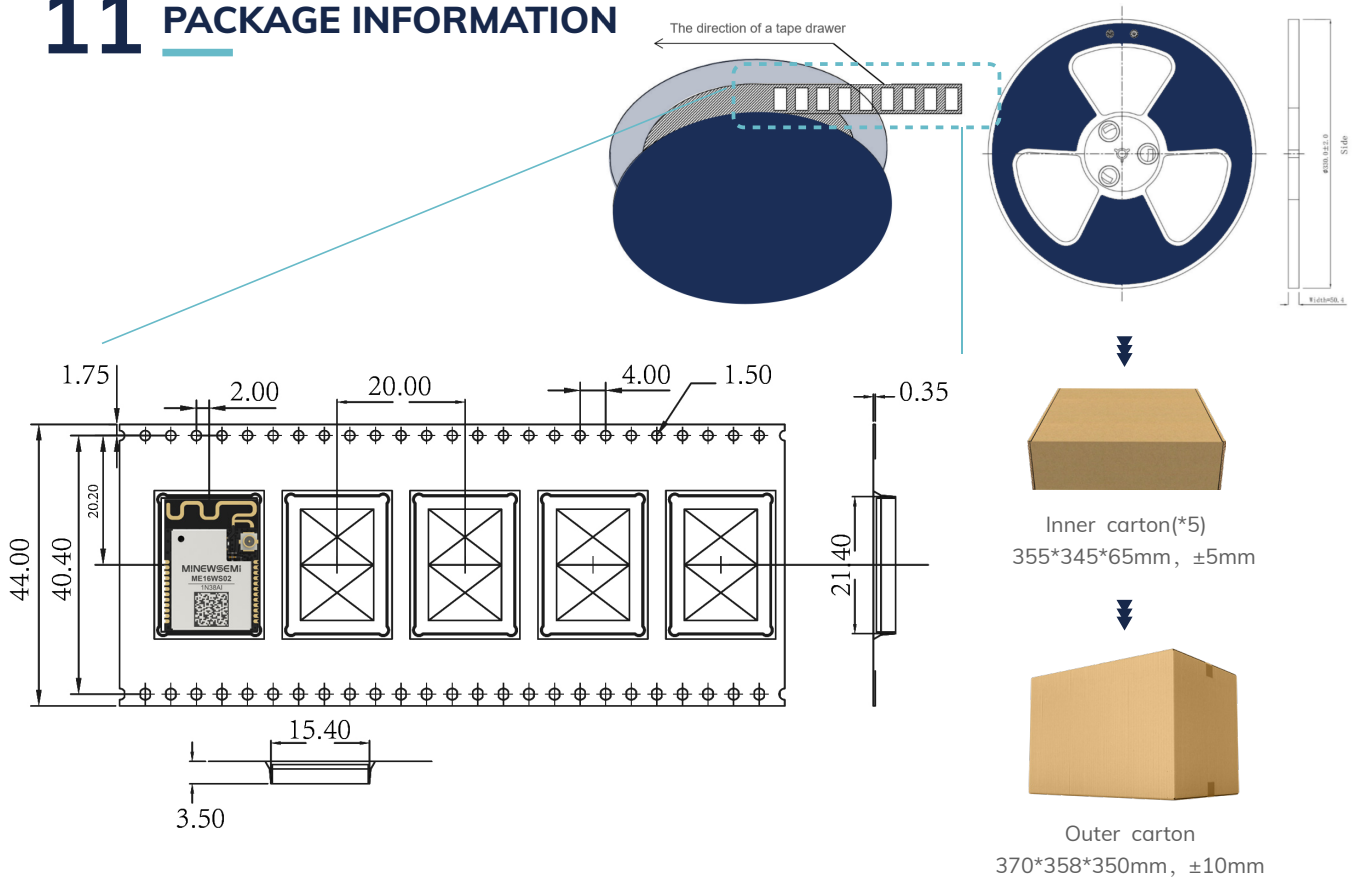



# 11 PACKAGE INFORMATION

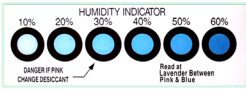

## Remarks

General material list for FCL packaging:

			
Carrier tape packaging tray	Humidity Indicator (1 pcs/bag)	Desiccant (placed in a vacuum bag)	Vacuum bag
		<b>Other:</b>	
Inner carton(*5) 355*345*65mm, ±5mm	Outer carton 370*358*350mm, ±10mm	Moisture-proof label (attached to the vacuum bag) Certification label (attached to the vacuum bag) Outer box label	

 Default unit: mm Default tolerance: ±0.1

Packing detail	Specification	Net weight	Gross weight	Dimension
ME16WS02	800PCS	-	-	W=44mm, T=0.35mm

 Note: Default weight tolerance all are within 10g (except the special notes)

## 12 STORAGE CONDITIONS

- **Please use this product within 6 months after signing the receipt.**
  - This product should be stored without opening the package at an ambient temperature of 5~35°C and a humidity of 20~70%RH.
  - This product should be left for more than 6 months after receipt and should be confirmed before use.
  - The product must be stored in a non-corrosive gas (Cl<sub>2</sub>, NH<sub>3</sub>, SO<sub>2</sub>, NO<sub>x</sub>, etc.).
  - To avoid damaging the packaging material, do not apply any excessive mechanical shocks, including but not limited to sharp objects adhering to the packaging material and product dropping.
- **This product is suitable for MSL2 (based on JEDEC standard J-STD-020).**
  - After opening the package, the product must be stored at ≤30°C/<60%RH. It is recommended to use the product within 3-6 months after opening the package.
  - When the color of the indicator in the package changes, the product should be baked before welding.
- **Baking is not required for one year if exposure is limited to <30°C and 60%RH. Refer to MSL2 for exposure criteria for moisture sensitivity level. If exposed to (≥168h@85°C/60%RH) conditions or stored for more than one year, recommended baking conditions.**
  1. 120 +5/-5°C, 8 hours, 1 time  
Products must be baked individually on heat-resistant trays because the materials (base tape, reel tape, and cover tape) are not heat-resistant, and the packaging material may be deformed at temperatures of 120°C;
  2. 90°C +8/-0°C, 24hours, 1times  
The base tape can be baked together with the product at this temperature. Please pay attention to the uniformity of heat.

## 13 HANDLING CONDITIONS

- Be careful in handling or transporting products because excessive stress or mechanical shock may break products.
- Handle with care if products may have cracks or damages on their terminals. If there is any such damage, the characteristics of products may change. Do not touch products with bare hands that may result in poor solder ability and destroy by static electrical charge.

## 14 QUALITY

Cognizant of our commitment to quality, we operate our own factory equipped with state-of-the-art production facilities and a meticulous quality management system. We hold certifications for ISO9001, ISO14001, ISO27001, OHSAS18001, BSCI.

Every product undergoes stringent testing, including transmit power, sensitivity, power consumption, stability, and aging tests. Our fully automated module production line is now in full operation, boasting a production capacity in the millions, capable of meeting high-volume production demands.

## 15 COPYRIGHT STATEMENT

This manual and all the contents contained in it are owned by Shenzhen Minewsemi Co., Ltd. and are protected by Chinese laws and applicable international conventions related to copyright laws.

The certified trademarks included in this product and related documents have been licensed for use by MinewSemi. This includes but is not limited to certifications such as BQB, RoHS, REACH, CE, FCC, BQB, IC, SRRC, TELEC, WPC, RCM, WEEE, etc. The respective textual trademarks and logos belong to their respective owners. For example, the Bluetooth® textual trademark and logo are owned by Bluetooth SIG, Inc. Other trademarks and trade names are those of their respective owners. Due to the small size of the module product, the "®" symbol is omitted from the Bluetooth Primary Trademarks information in compliance with regulations.

The company has the right to change the content of this manual according to the technological development, and the revised version will not be notified otherwise. Without the written permission and authorization of the company, any individual, company, or organization shall not modify the contents of this manual or use part or all of the contents of this manual in other ways. Violators will be held accountable in accordance with the law.

## 16 RELATED DOCUMENTS

- [MinewSemi\\_Product\\_Naming\\_Reference\\_Manual\\_V1.0](https://en.minewsemi.com/file/MinewSemi_Product_Naming_Reference_Manual_EN.pdf)  
[https://en.minewsemi.com/file/MinewSemi\\_Product\\_Naming\\_Reference\\_Manual\\_EN.pdf](https://en.minewsemi.com/file/MinewSemi_Product_Naming_Reference_Manual_EN.pdf)
- [MinewSemi\\_Connectivity\\_Module\\_Catalogue\\_V2.0](https://en.minewsemi.com/file/MinewSemi_Connectivity_Module_Catalogue_EN.pdf)  
[https://en.minewsemi.com/file/MinewSemi\\_Connectivity\\_Module\\_Catalogue\\_EN.pdf](https://en.minewsemi.com/file/MinewSemi_Connectivity_Module_Catalogue_EN.pdf)



For product change notifications and regular updates of Minewsemi documentation, please register on our website: [www.minewsemi.com](http://www.minewsemi.com)

# MINEWSEMI



### SHENZHEN MINEWSEMI CO., LTD.



0086-755-2801 0353



<https://minewsemi.com>



[minewsemi@minew.com](mailto:minewsemi@minew.com)



<https://store.minewsemi.com>



No.8, Qinglong Road, Longhua District, Shenzhen, China